

TRACTION DIESEL

# COURS POUR ELÈVES-CONDUCTEURS

Livre III

*Le moteur diesel et la  
transmission électrique*

Leçons 97 à 144

PLANCHES









TRANSMISSION ELECTRIQUE.

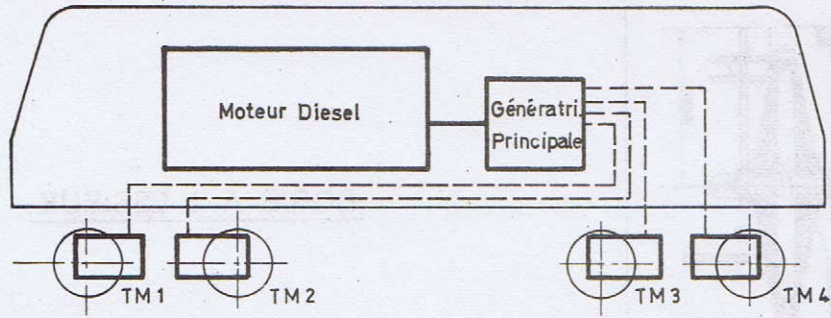

Fig. 97.02.1  
MOTEUR DE TRACTION.

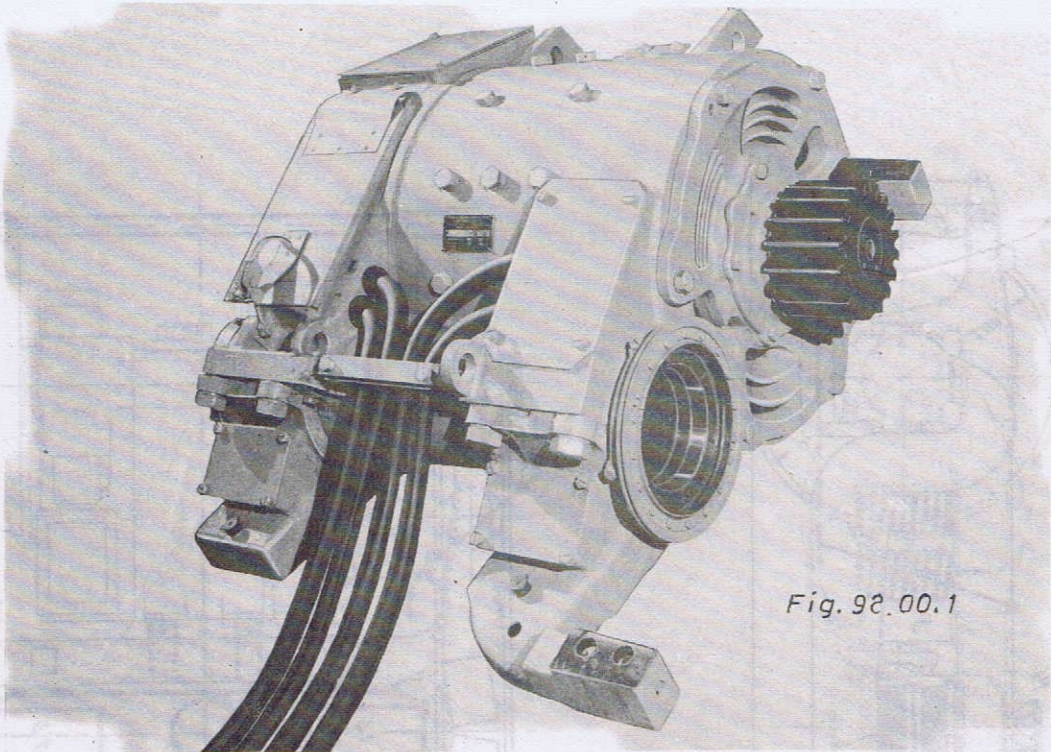

Fig. 92.00.1

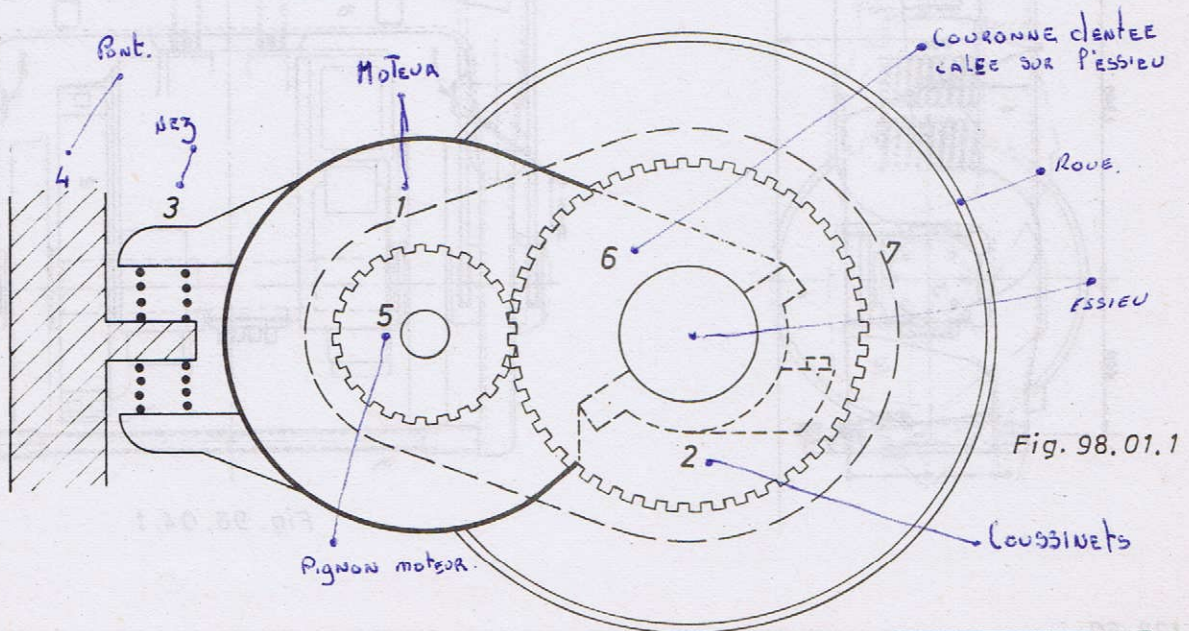

Fig. 98.01.1



BOGIE A 2 ESSIEUX.

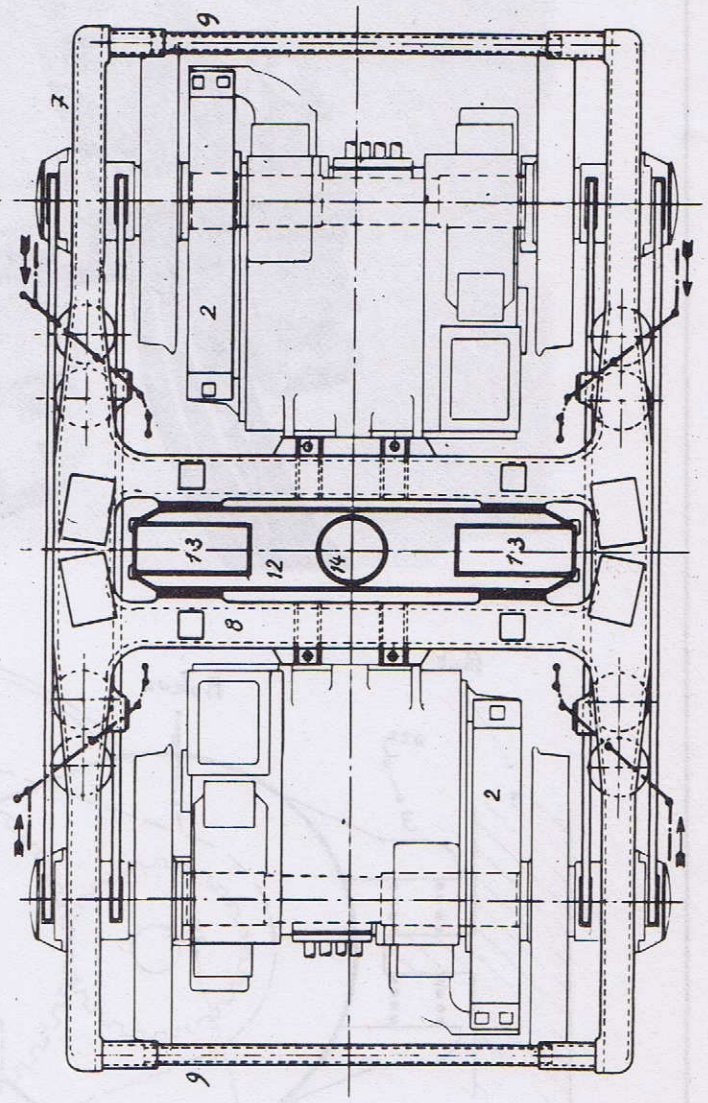
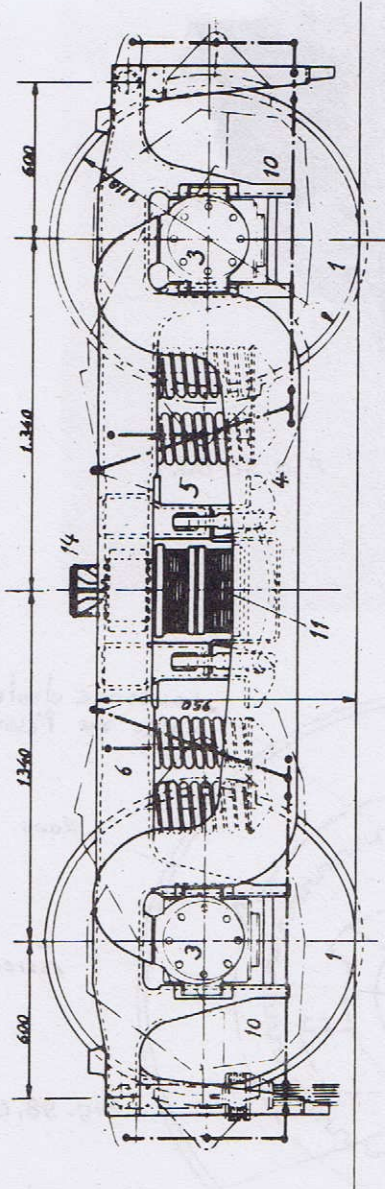
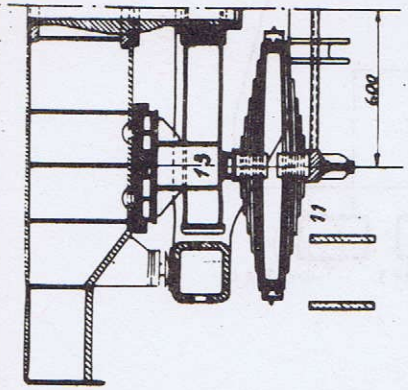

Fig. 98.04.1



BOGIE A TROIS ESSIEUX.

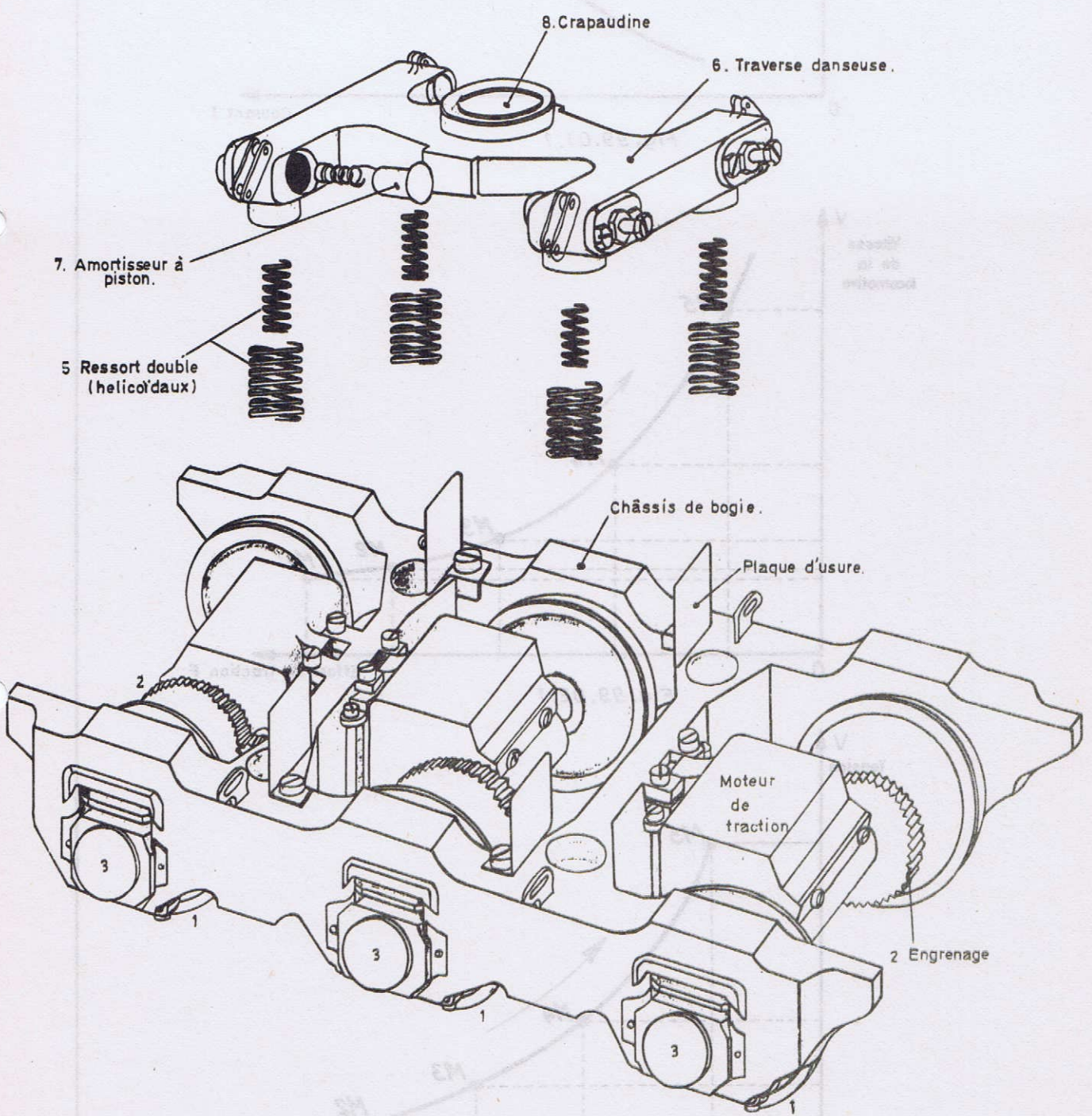

Fig. 98.05.1



# CARACTERISTIQUES DE LA TRANSMISSION ELECTRIQUE.

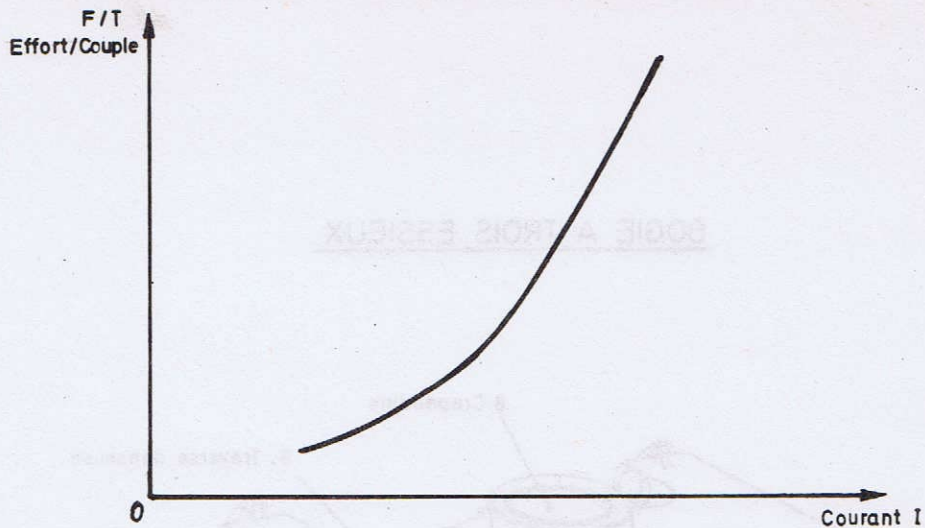

Fig. 99.01.1

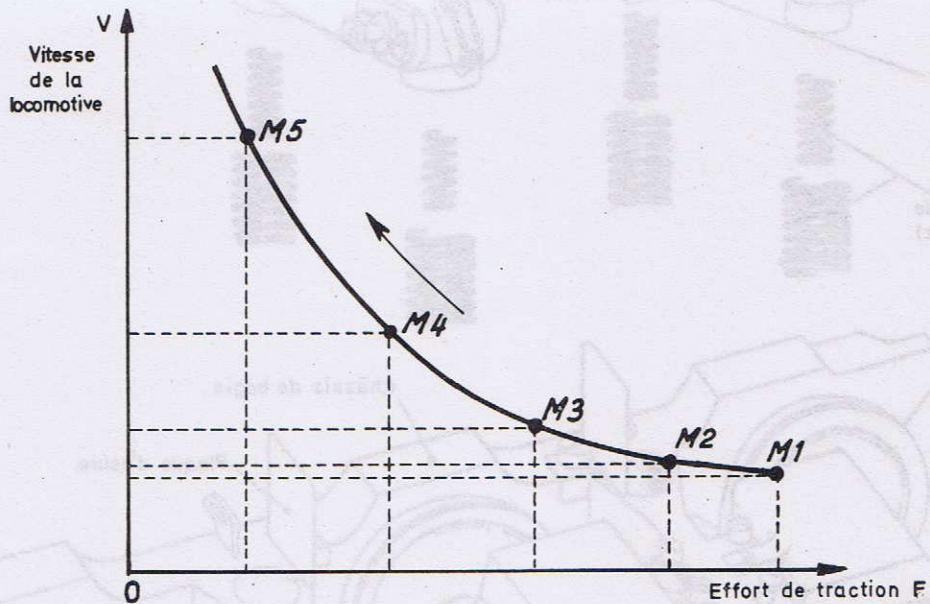

Fig. 99.02.1

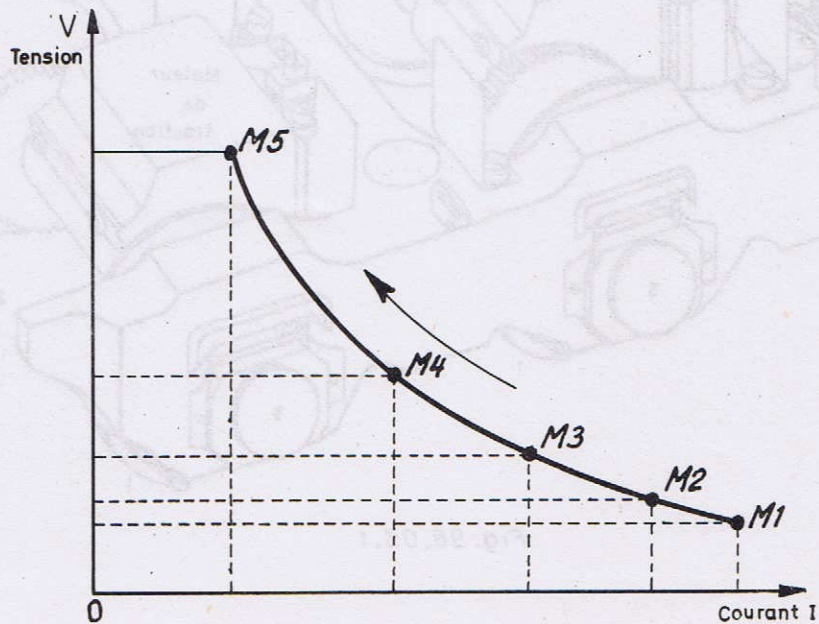

Fig. 99.03.1



CARACTERISTIQUE EXTERNE.

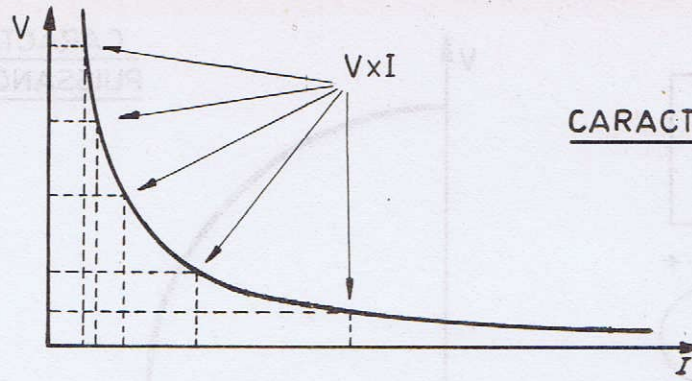

Fig.101.00.1

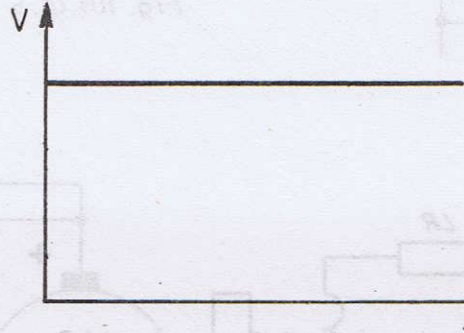
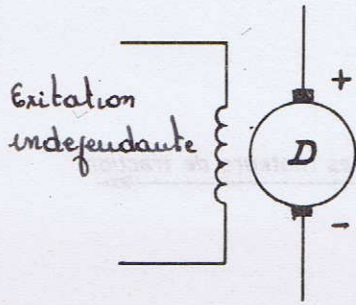

Fig.101.01.1

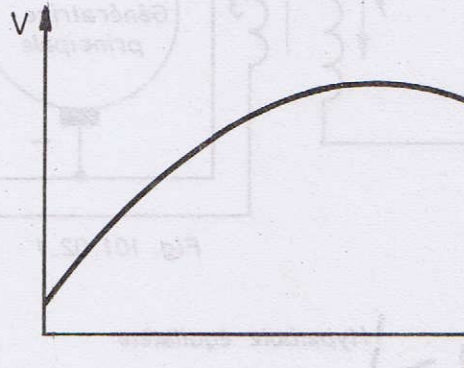
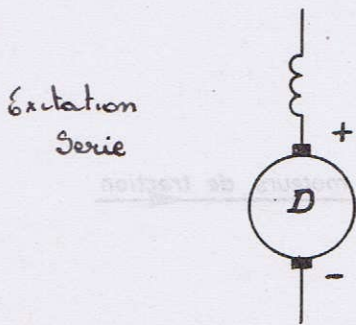

Fig.101.01.2

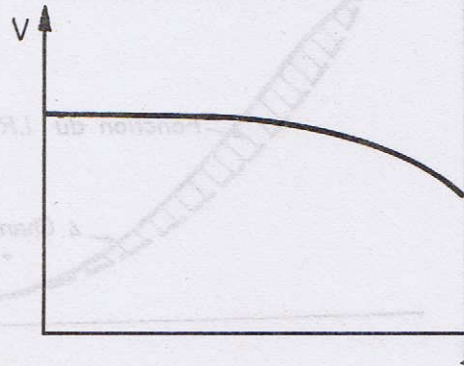
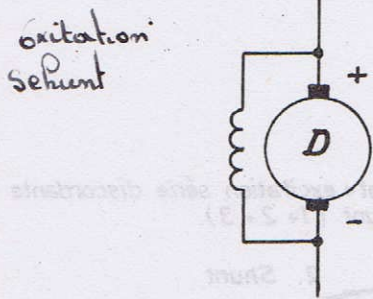

Fig.101.01.3

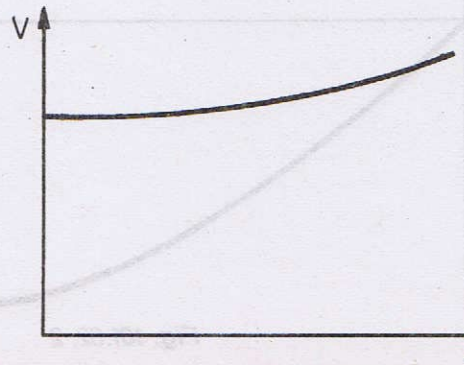
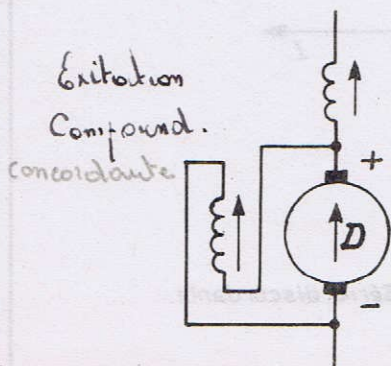

Fig.101.01.4



Excitation  
Compound  
discordante.

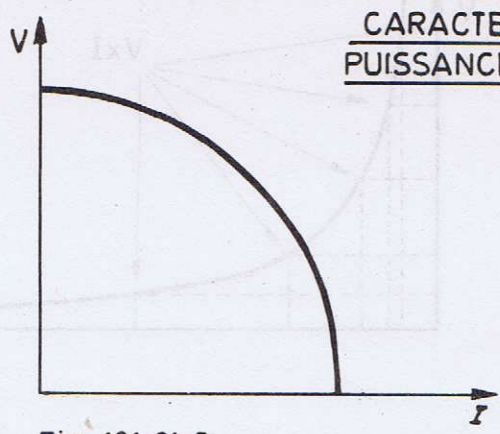
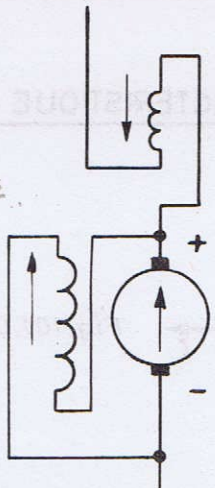

Fig. 101.01.5

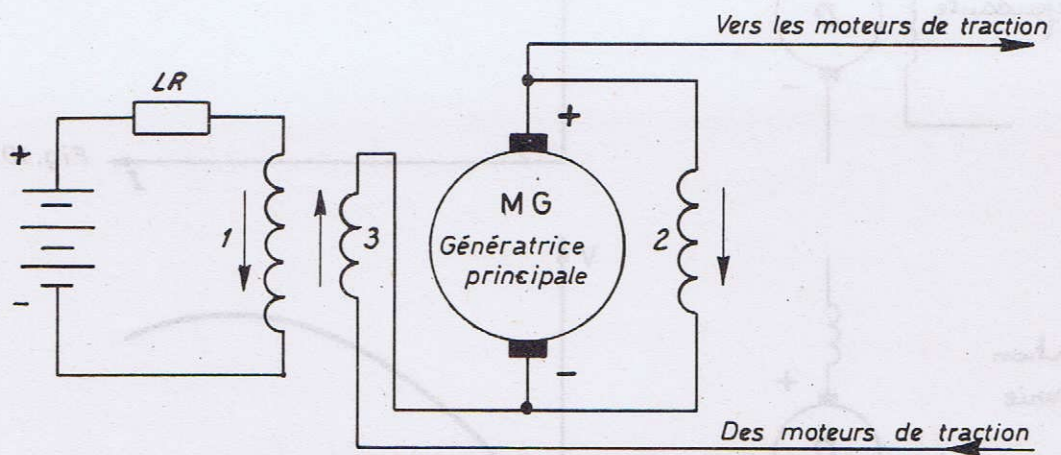

Fig. 101.02.1

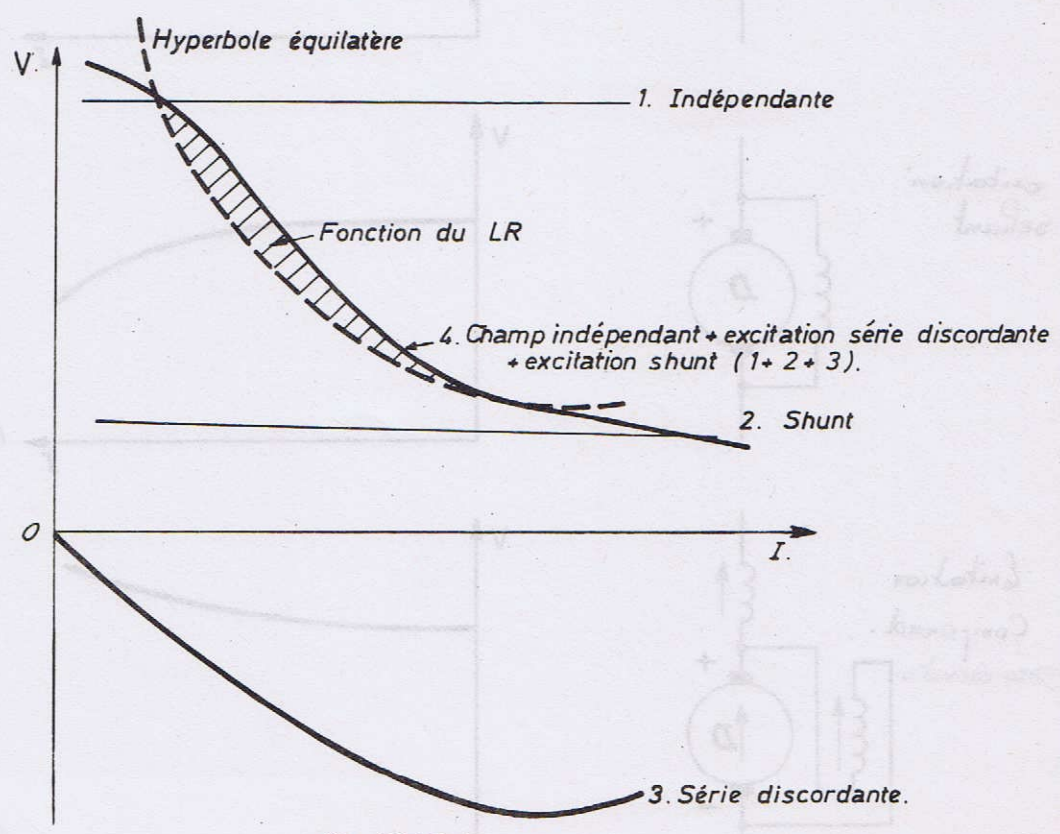

Fig. 101.02.2



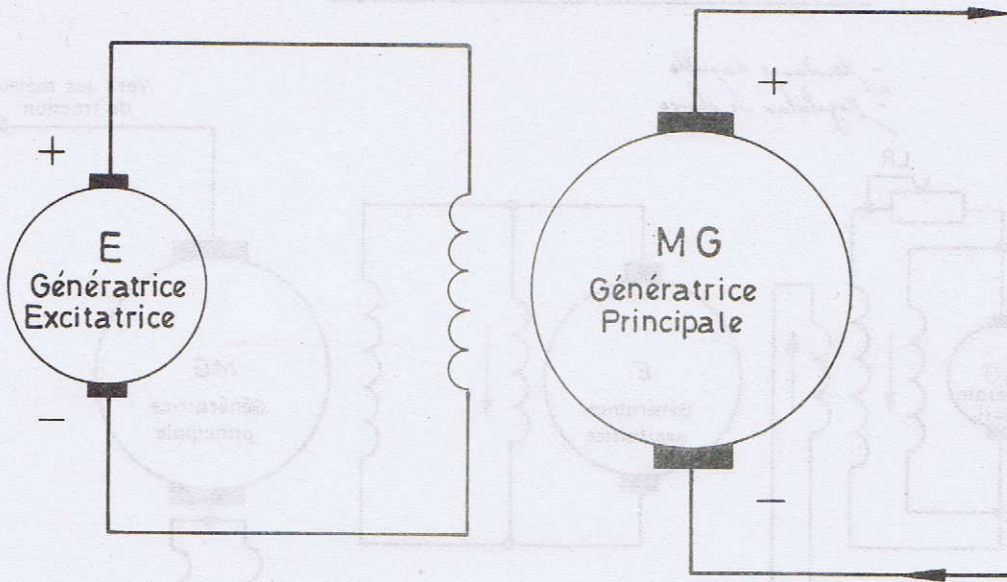

Fig. 102.01.1

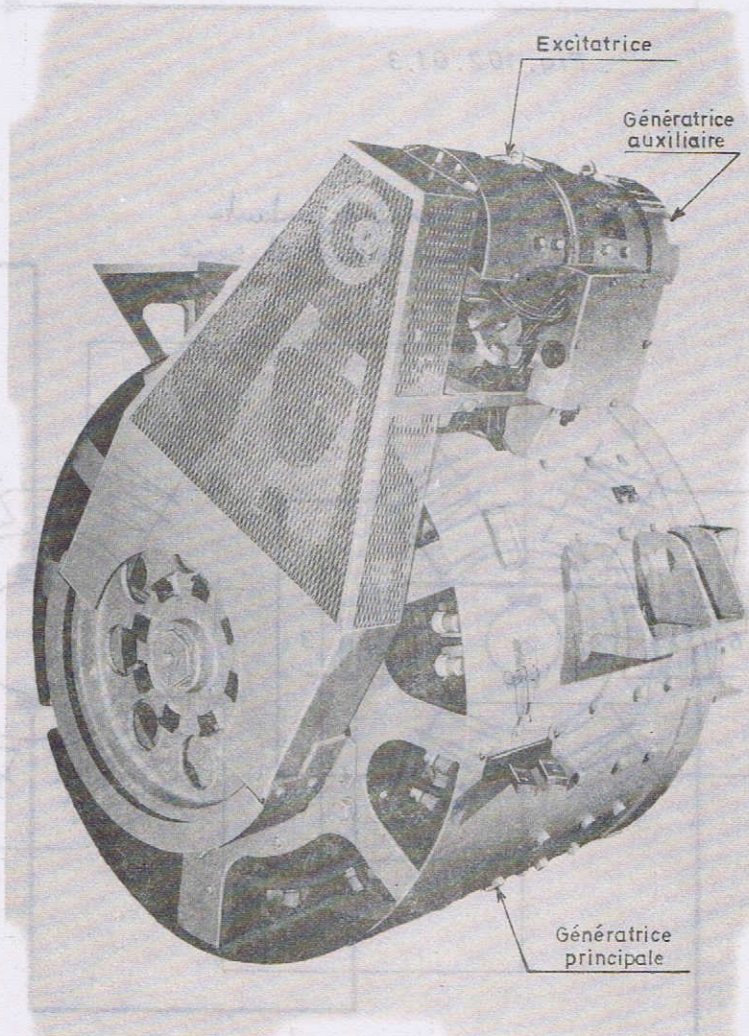

Fig. 102.01.2



SYSTEME ACEC - WESTINGHOUSE.

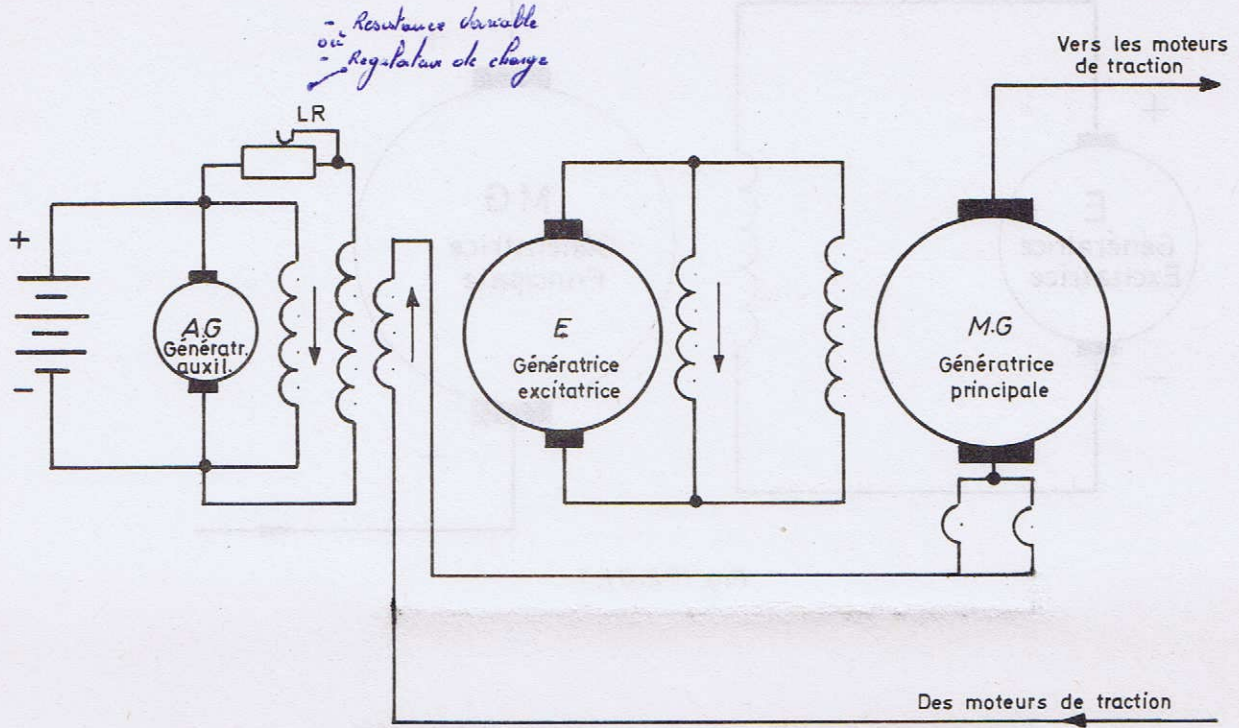

Fig. 102.01.3

*1, 2, 4, 5 : excitation indépendante  
3, 6 : excitation schunt et serie*

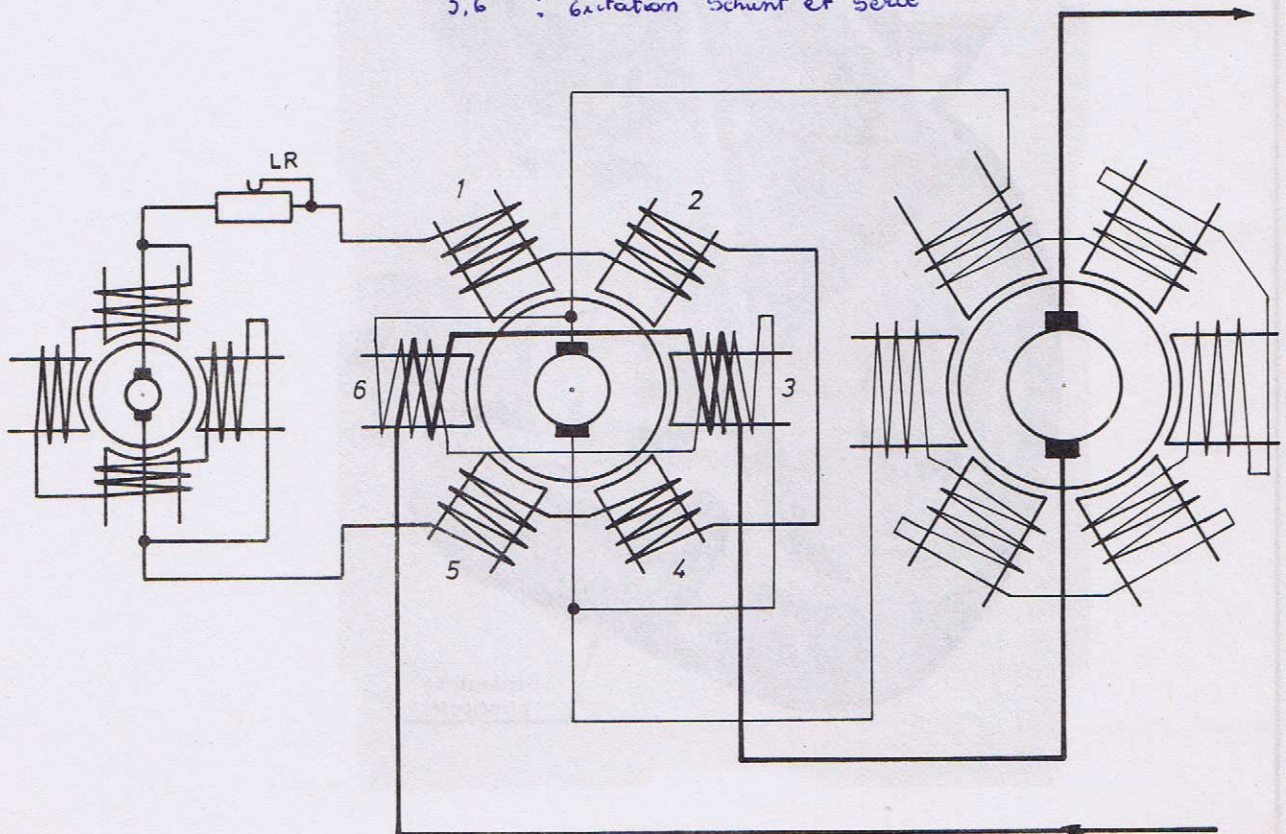

Fig. 102.01.4



### Réalisation de la courbe de puissance constante pour génératrice E.M.D.

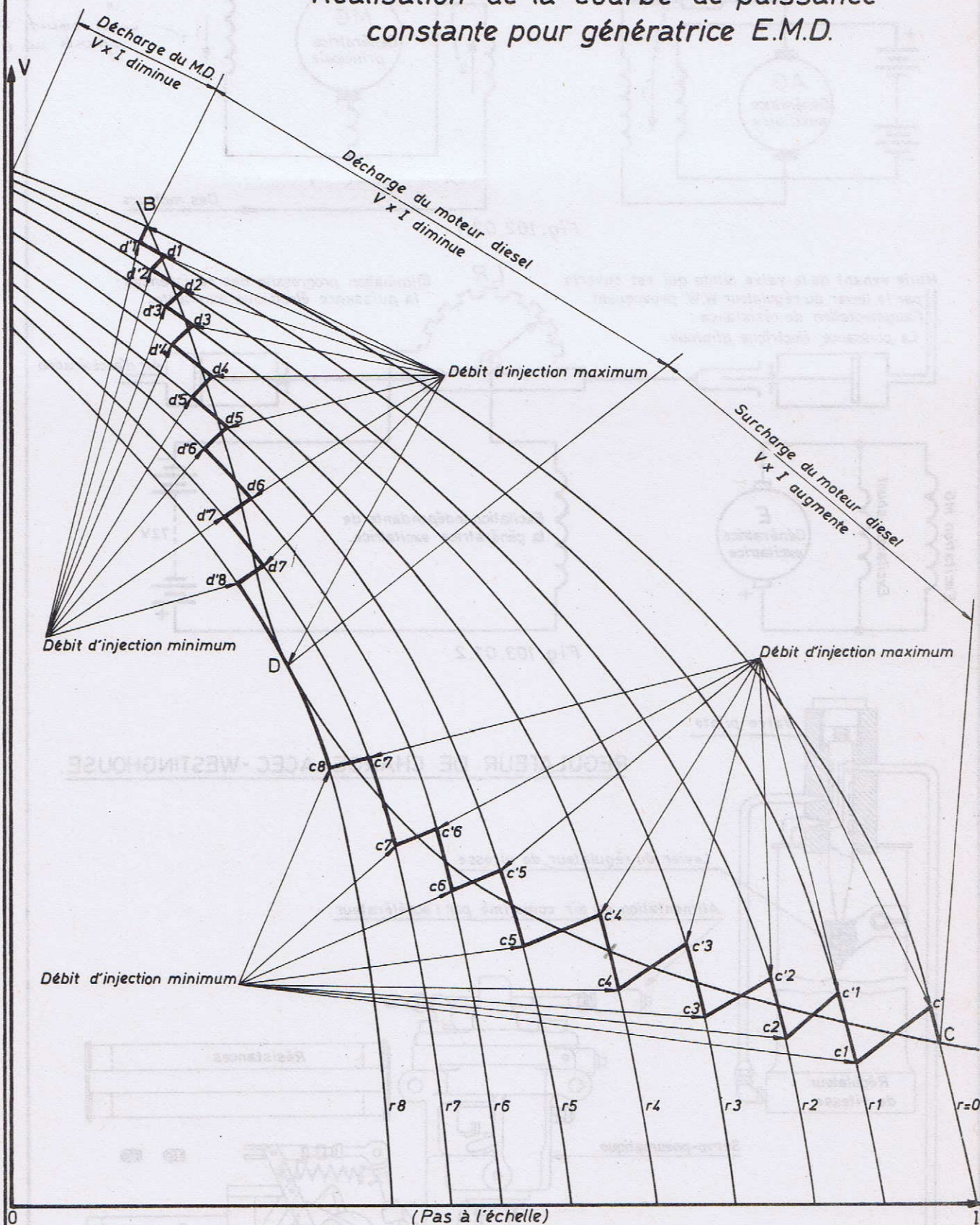

Fig. 102.02.2.

$c_4^4 - 8k/h - I_{max}$  jusqu'à max  
 jusqu'à D.



**SYSTEME EMD.**

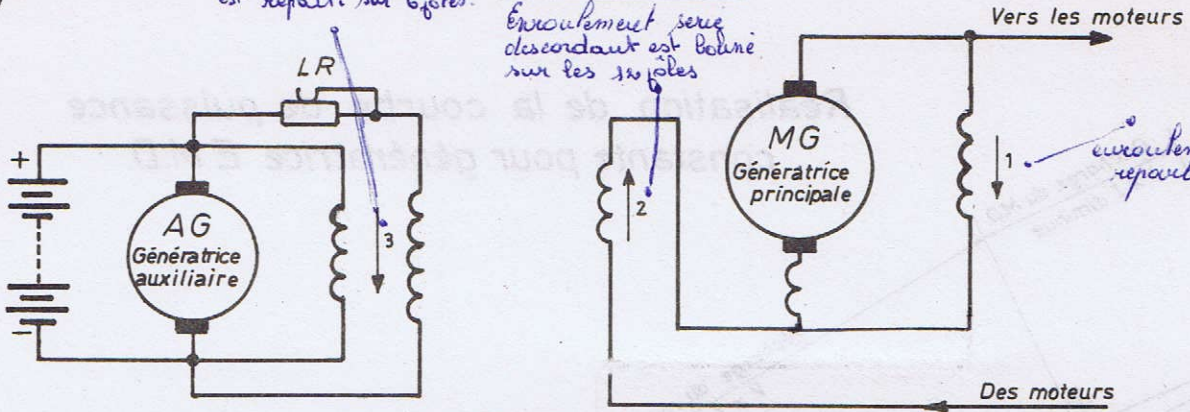

Fig. 102.02.1

Huile venant de la valve pilote qui est ouverte par le levier du régulateur W.W. provoquant l'augmentation de résistance : La puissance électrique diminue.

Elimination progressive des résistances : la puissance électrique augmente.

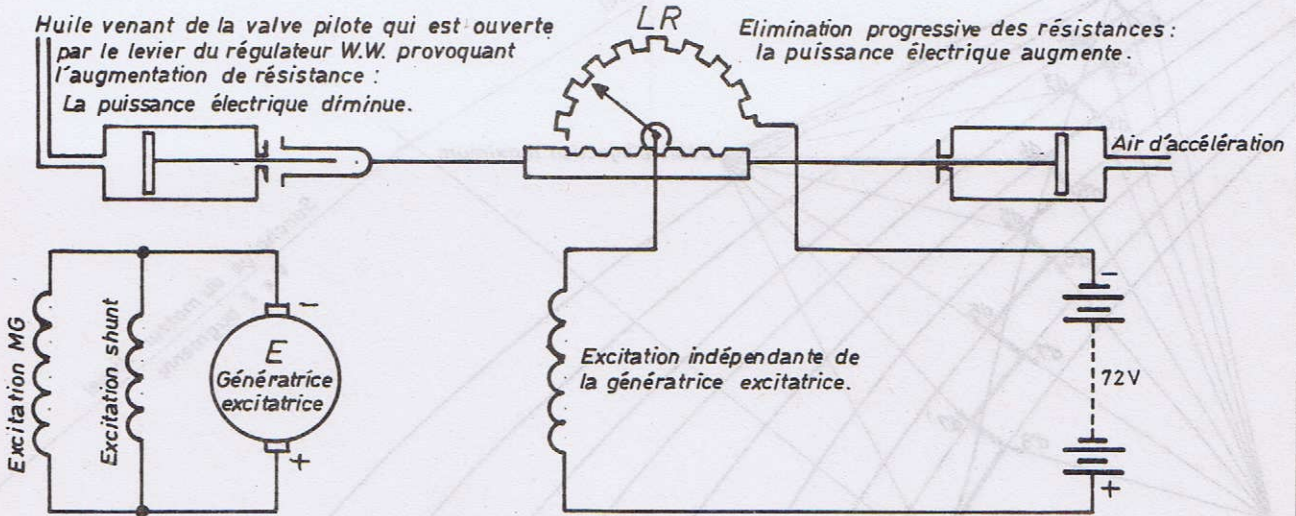

Fig. 103.01.2

**REGULATEUR DE CHARGE ACEC - WESTINGHOUSE.**

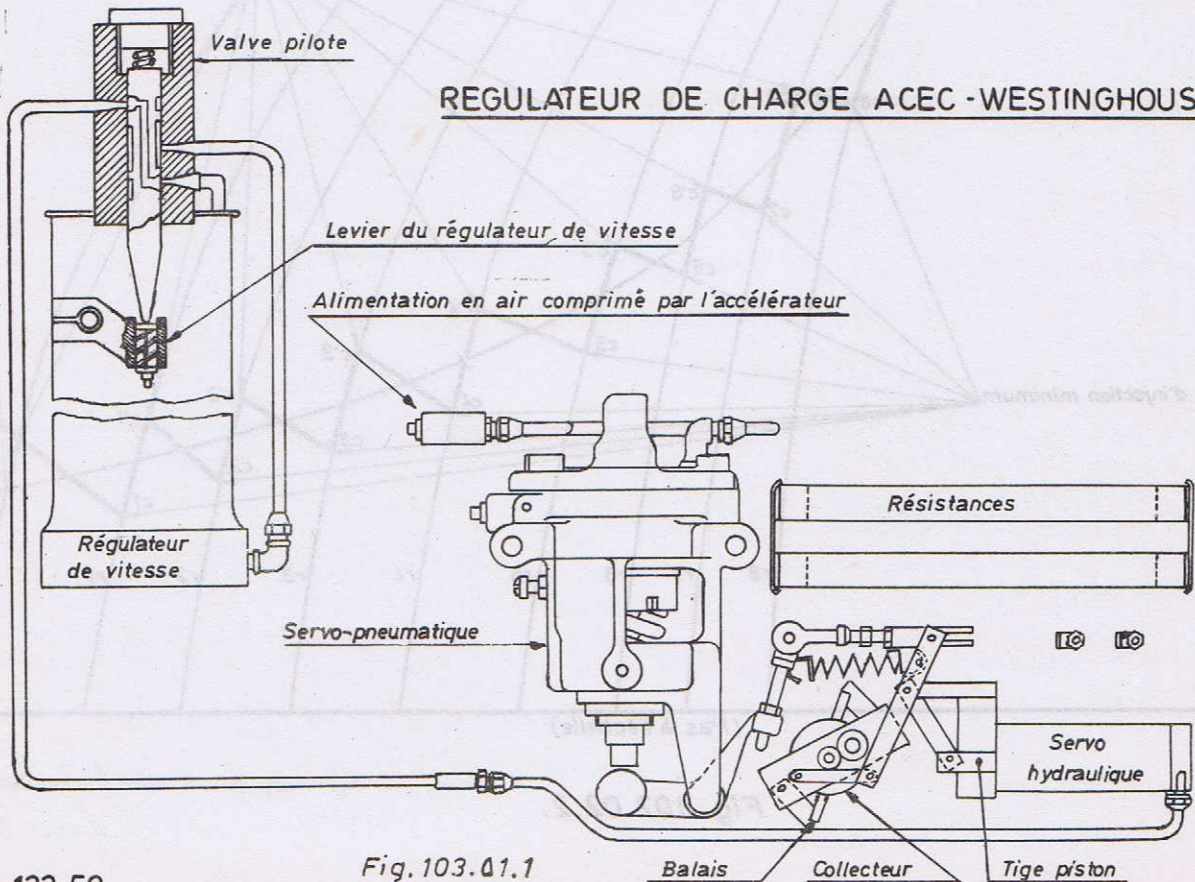

Fig. 103.01.1



REGULATEUR DE CHARGE EMD.

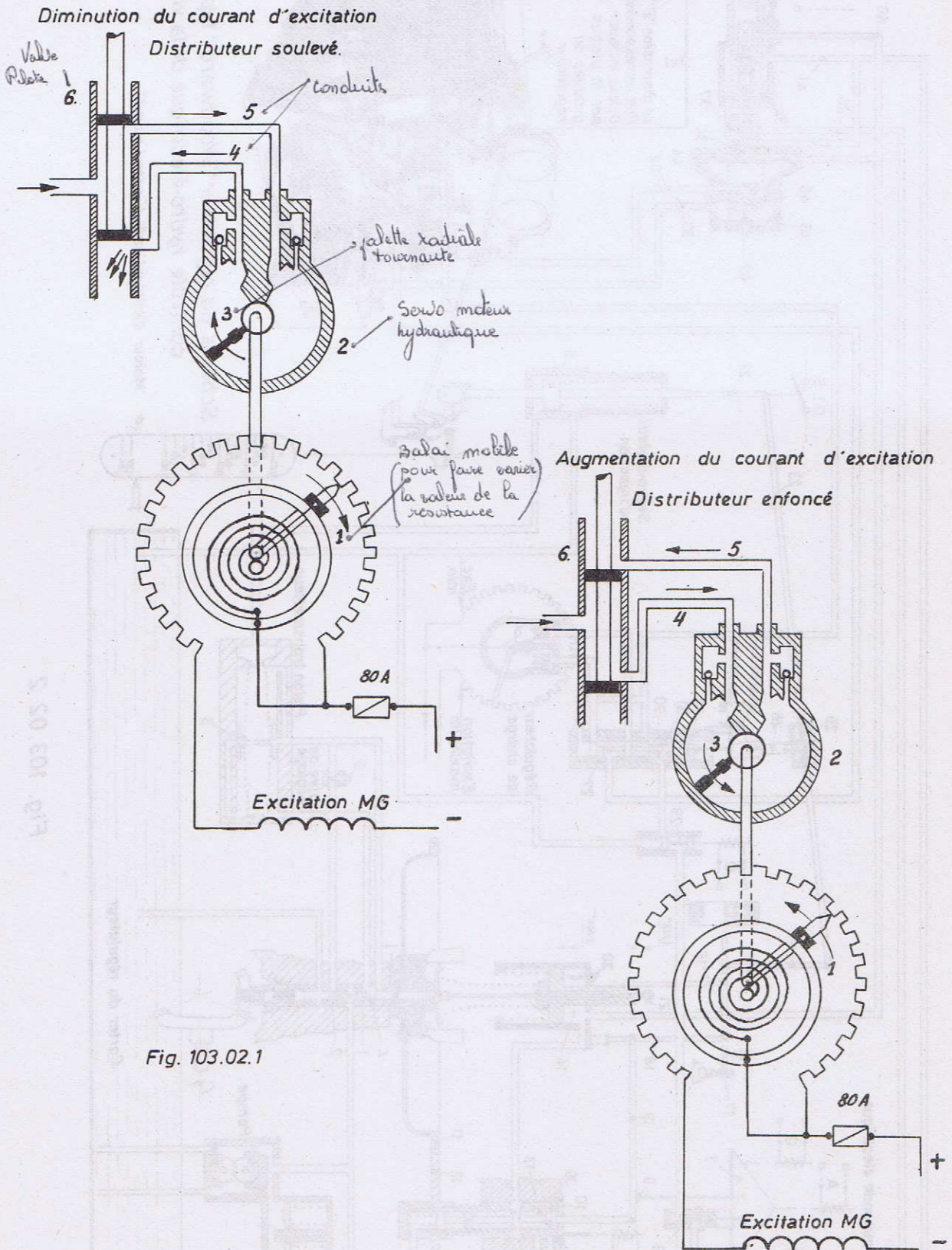

Fig. 103.02.1











REGULATEUR ELECTRONIQUE HL s.61.

Fig. 105.00.1.

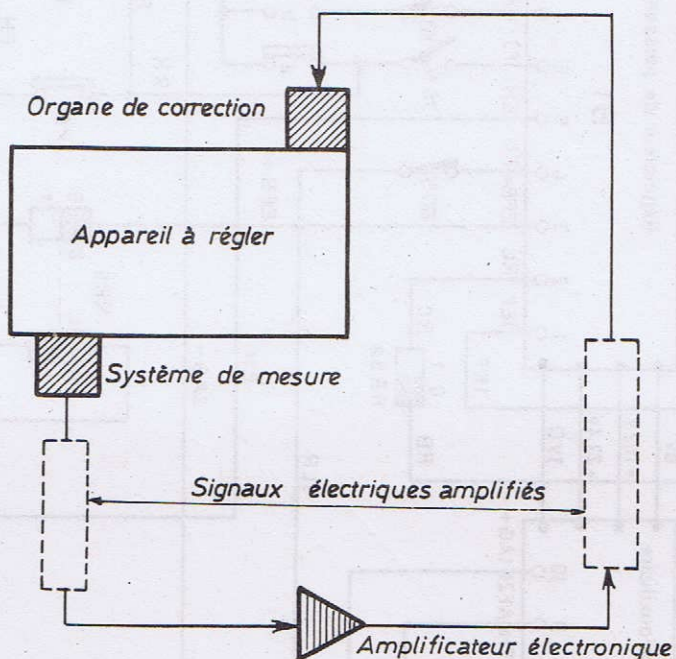
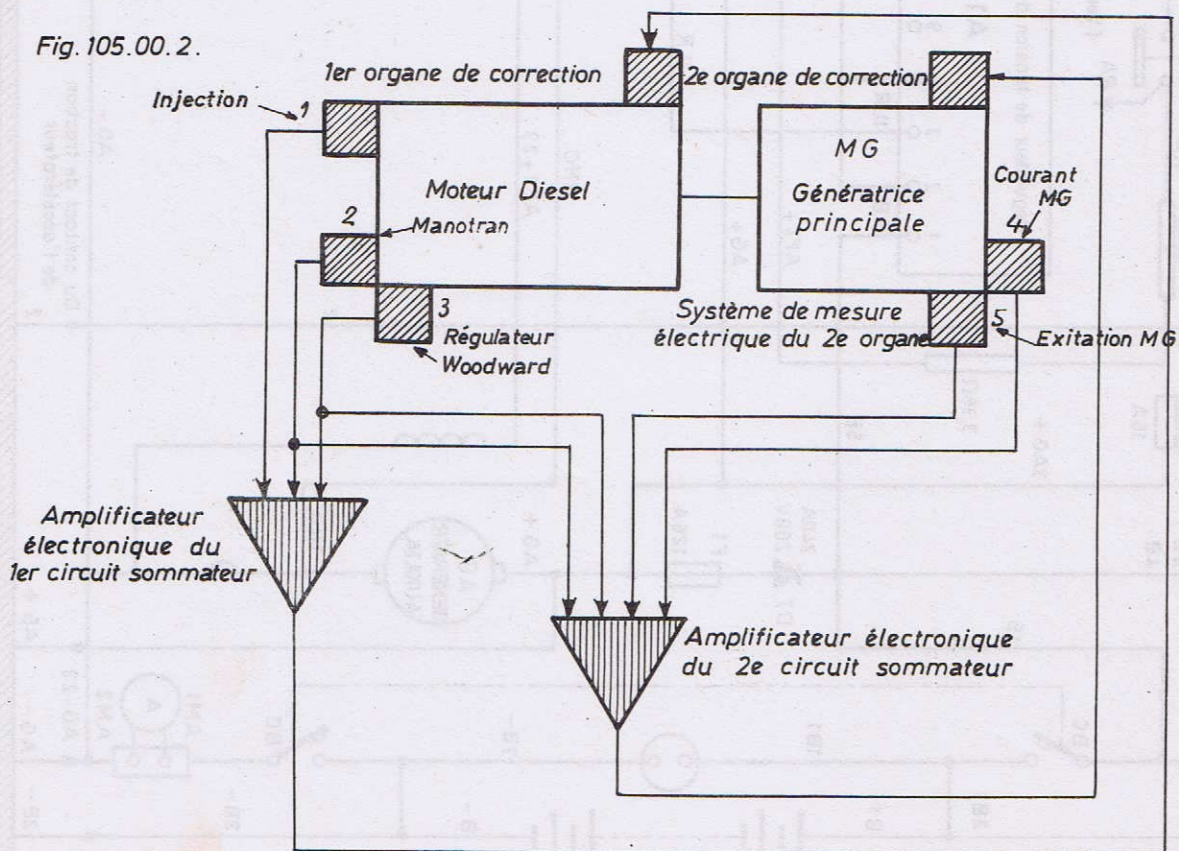

Fig. 105.00.2.





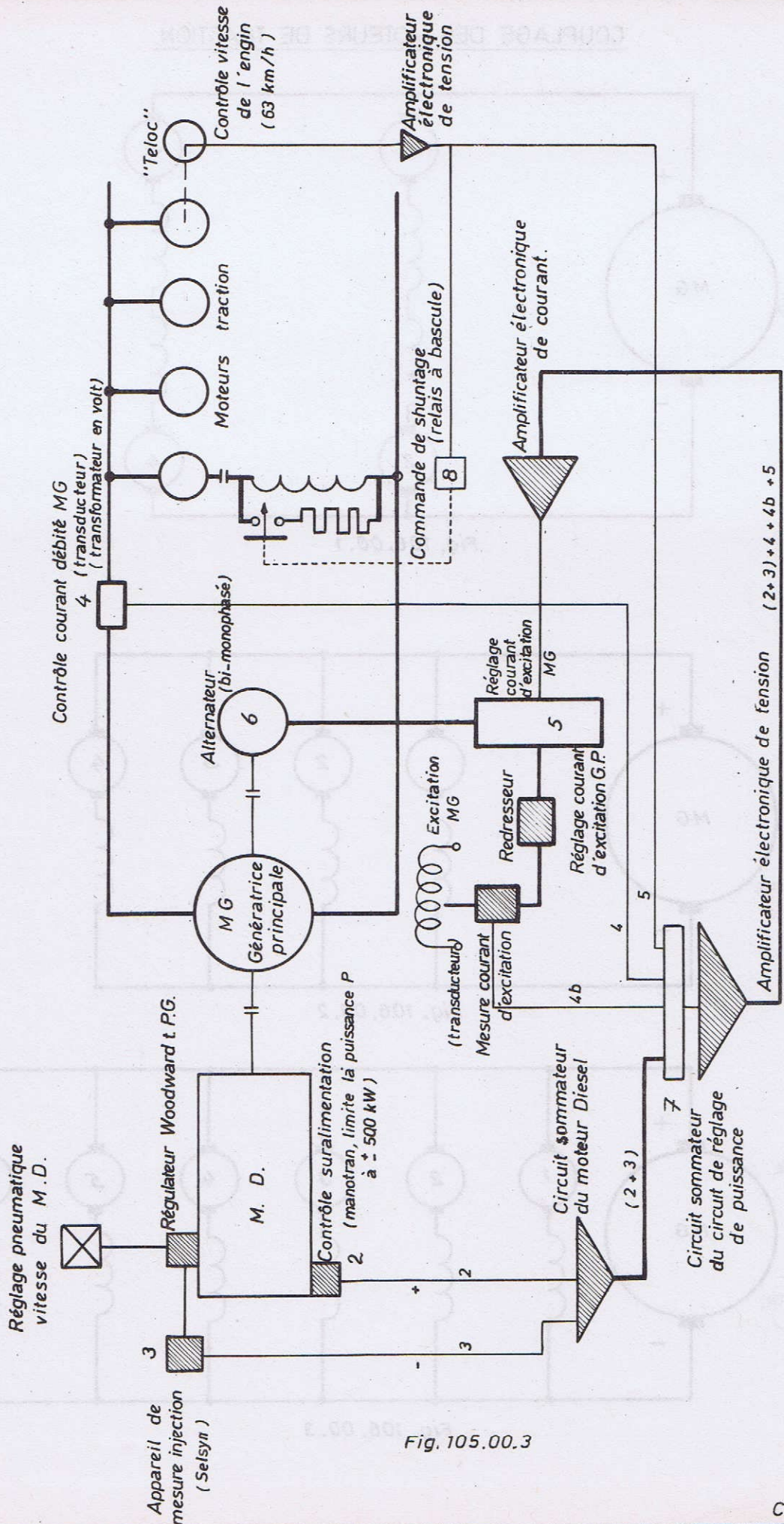

Fig. 105.00.3



COUPLAGE DES MOTEURS DE TRACTION.

type 59  
couplage unique  
série-parallèle  
4 crans de shuntage

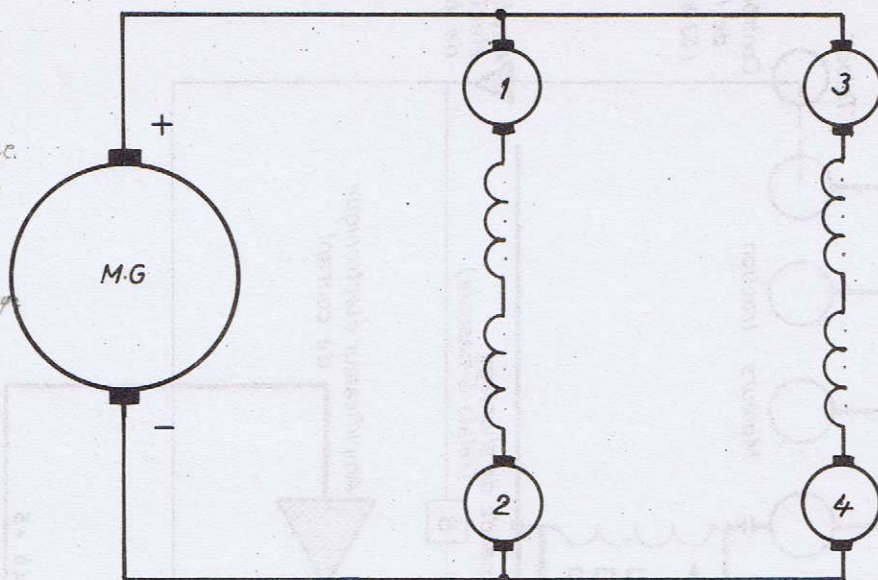

Fig. 106.00.1

type 60  
couplage parallèle  
4 crans de shuntage

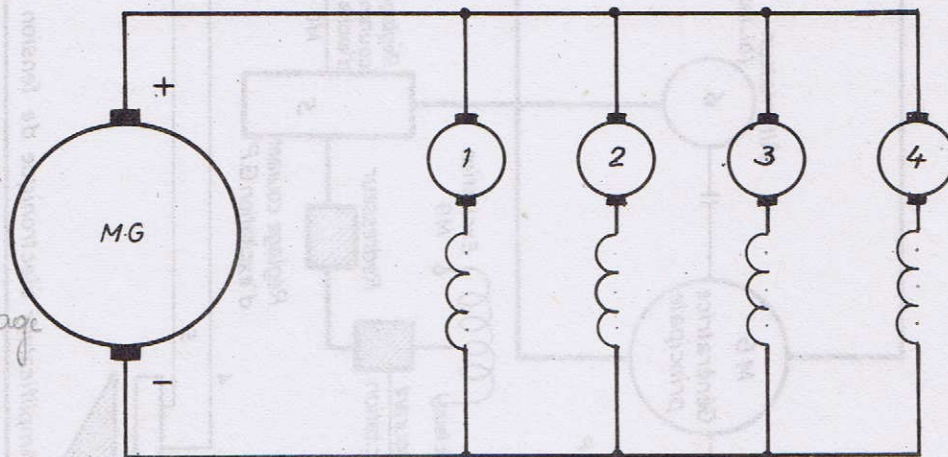

Fig. 106.00.2

type 51  
couplage parallèle  
1 cran de shuntage

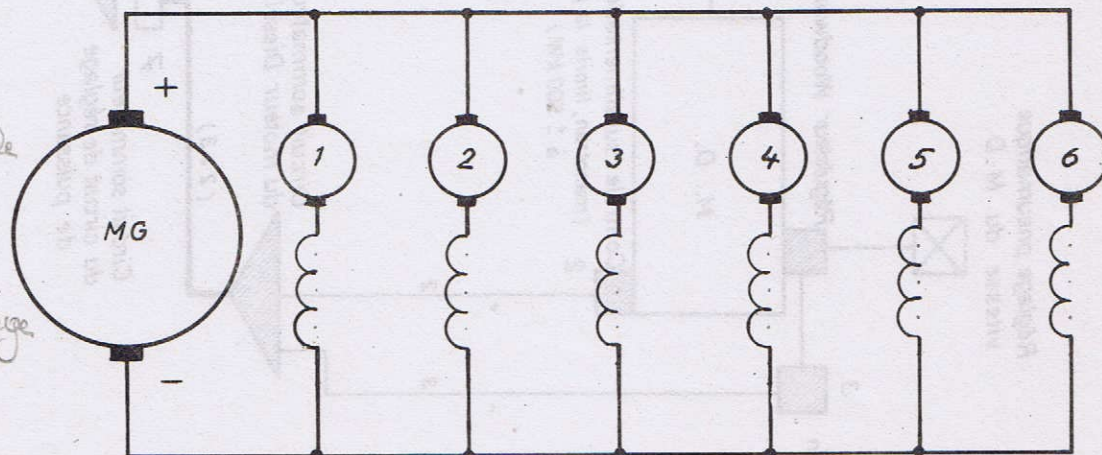

Fig. 106.00.3



1000 A de shuntage

Serie parallele

HLB 55

2100 A à 1200 A

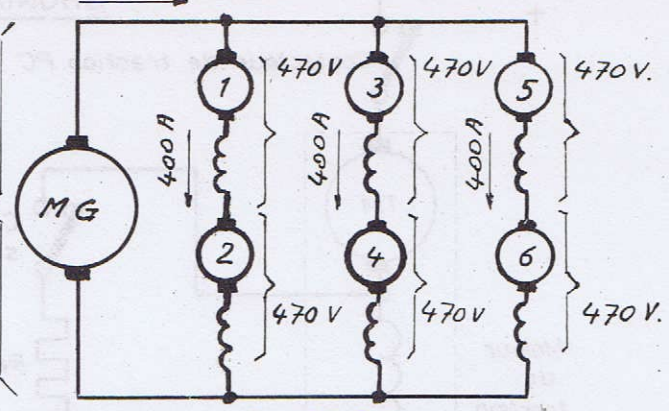

Fig. 106.01.1

transition

2400 A à 1200 A

Parallele

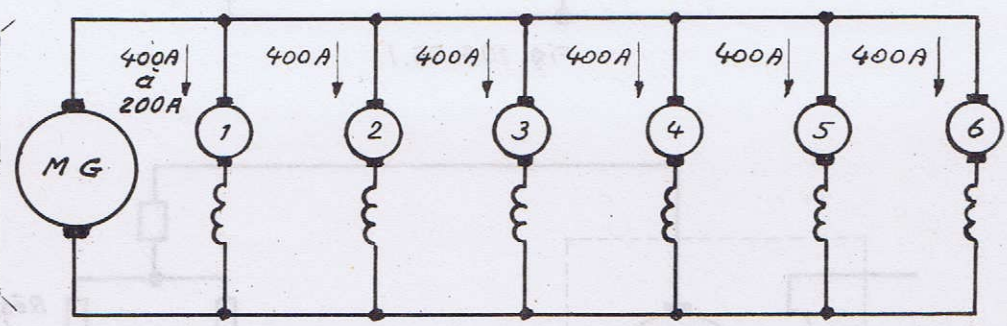

Fig. 106.01.2

Tension aux bornes de chaque moteur

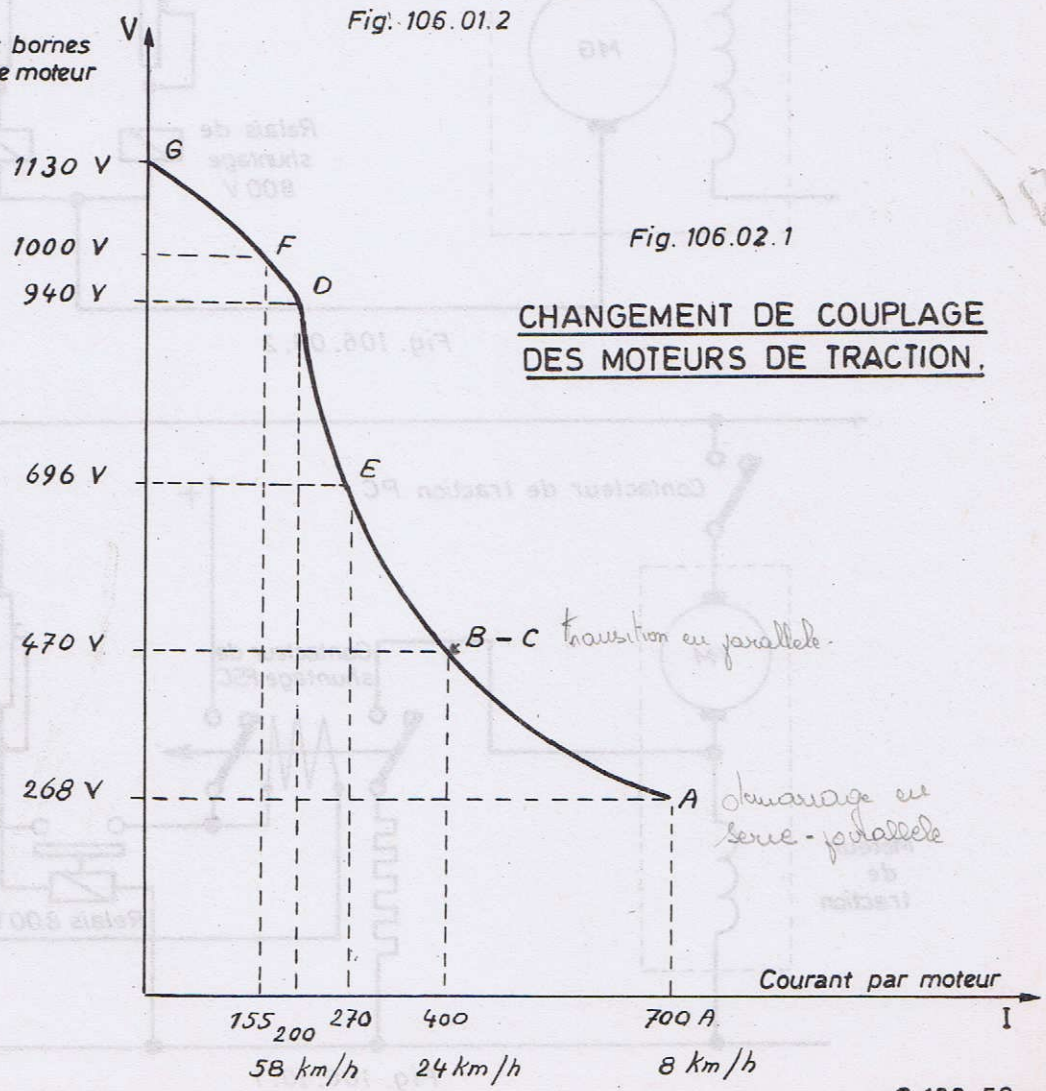

Fig. 106.02.1

CHANGEMENT DE COUPLAGE DES MOTEURS DE TRACTION.



SHUNTAGE.

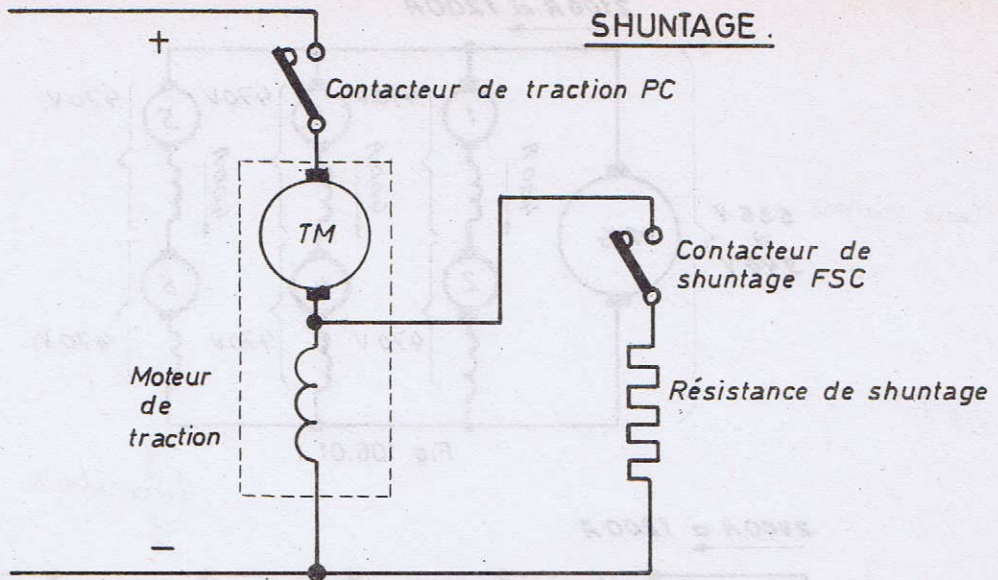

Fig. 106.05.1

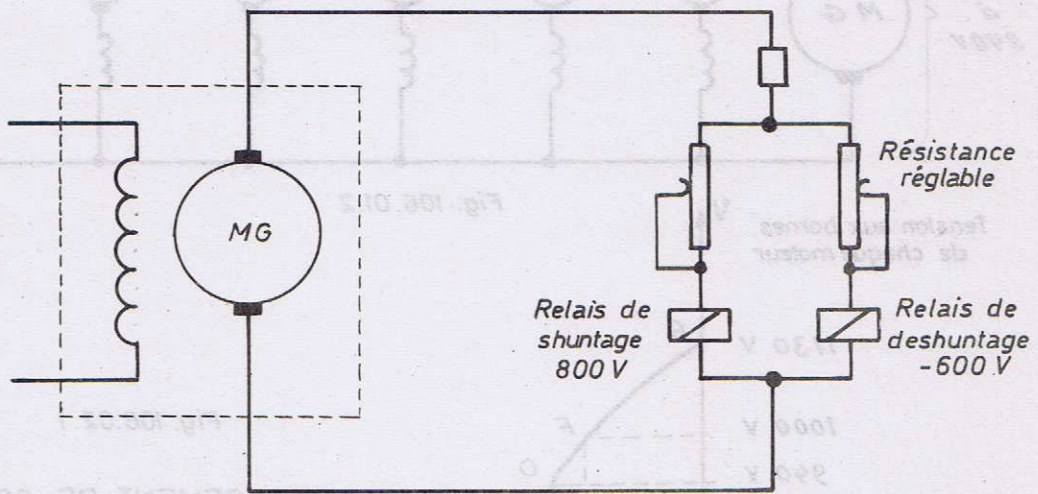

Fig. 106.09.2

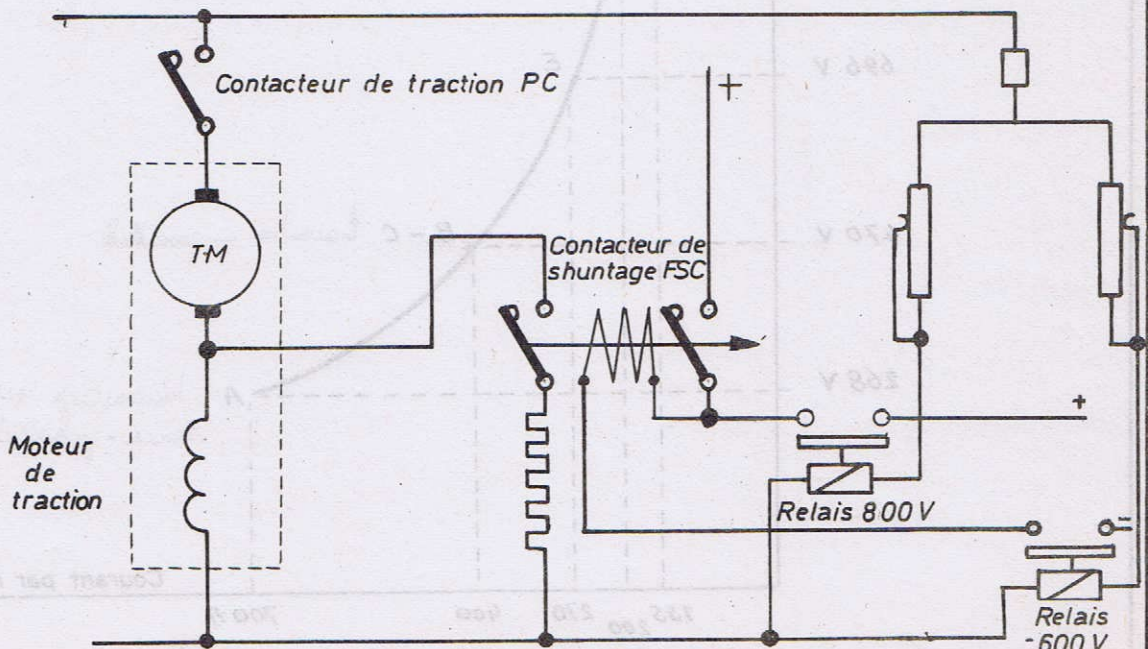

Fig. 106.10.1



*prend la vitesse au vare pour shunter*

### Commande du shuntage électronique

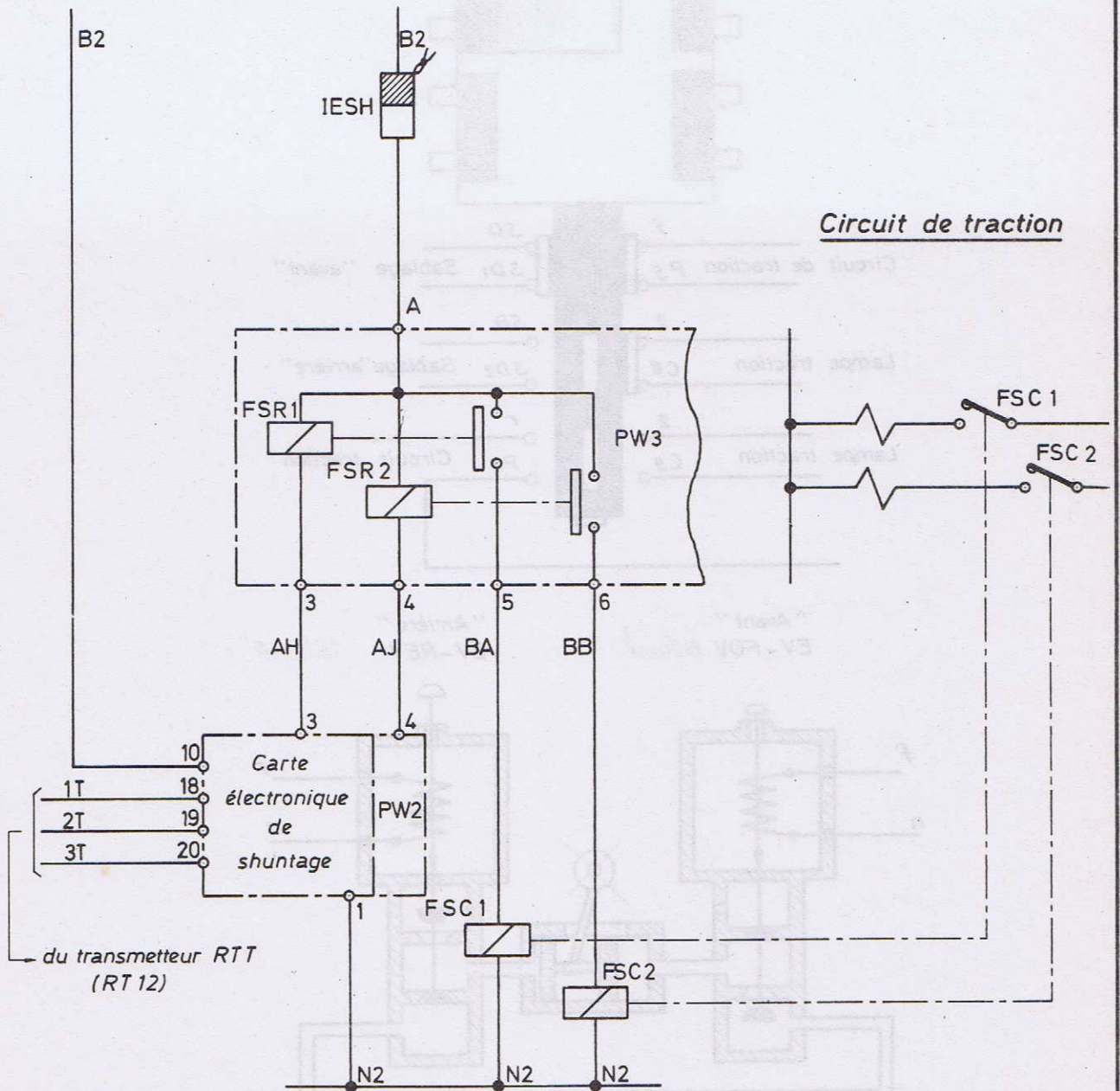

Fig. 106.09.1



TAMBOUR D'INVERSION.

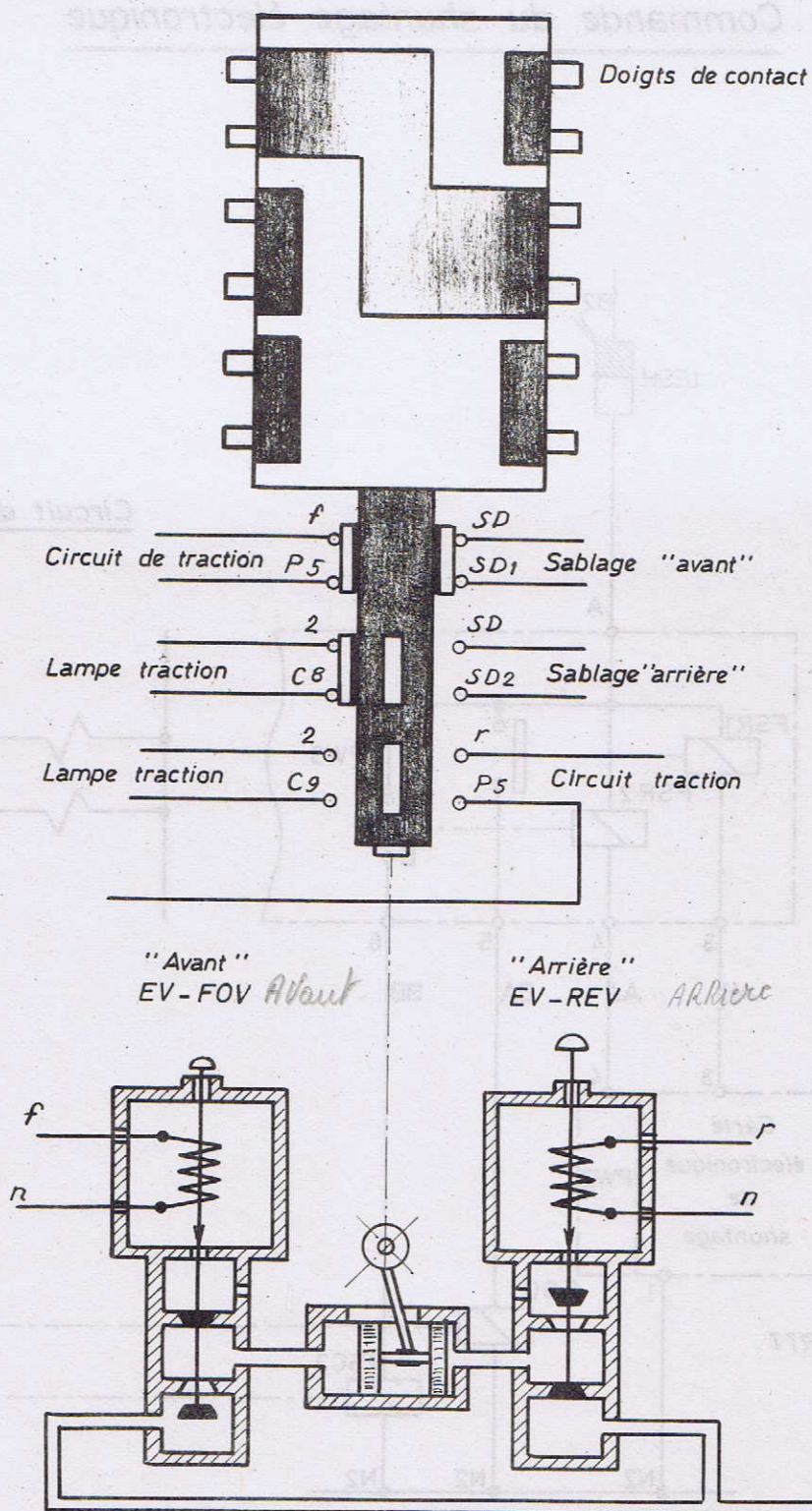

Fig. 107.02.1



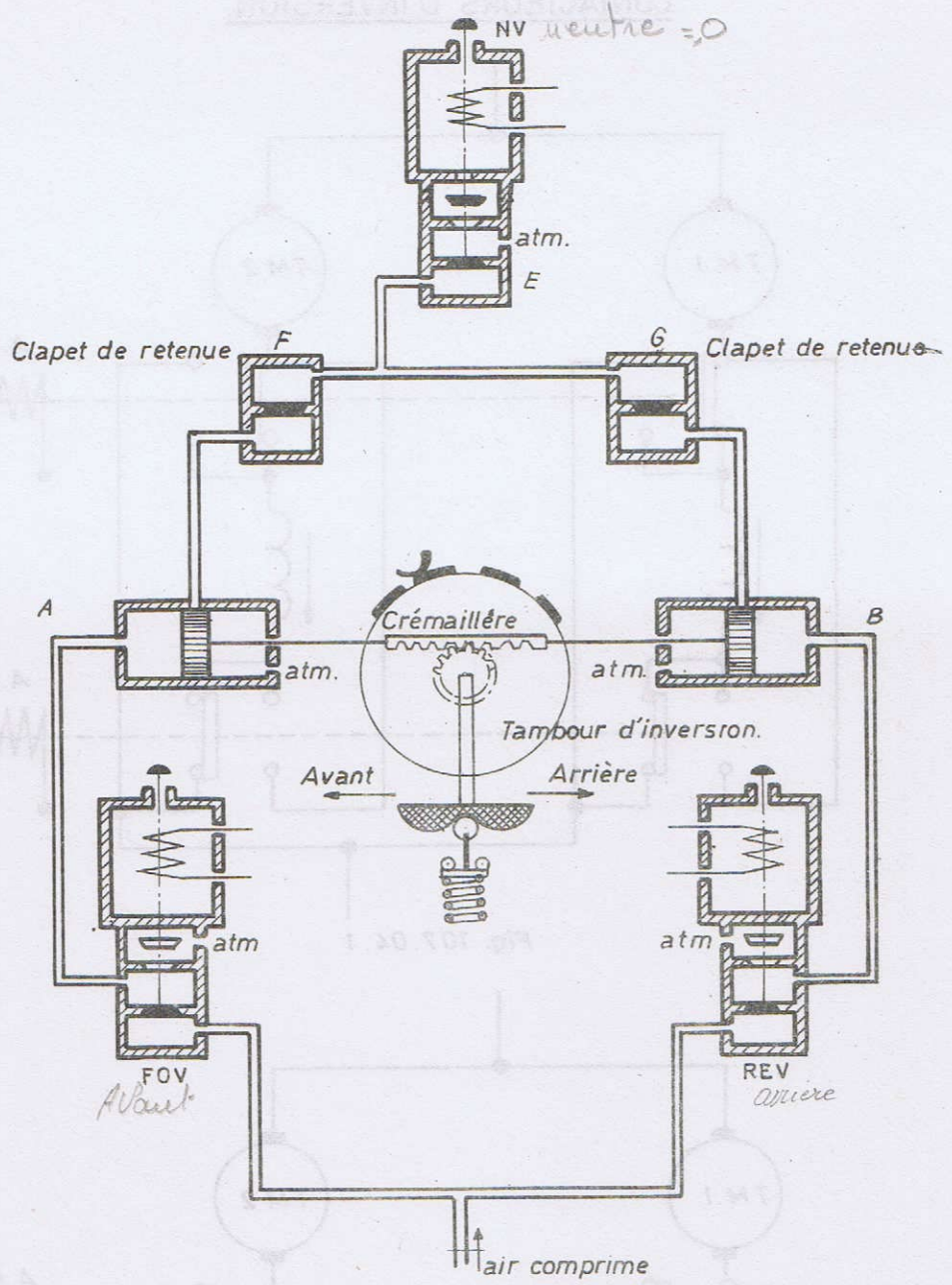
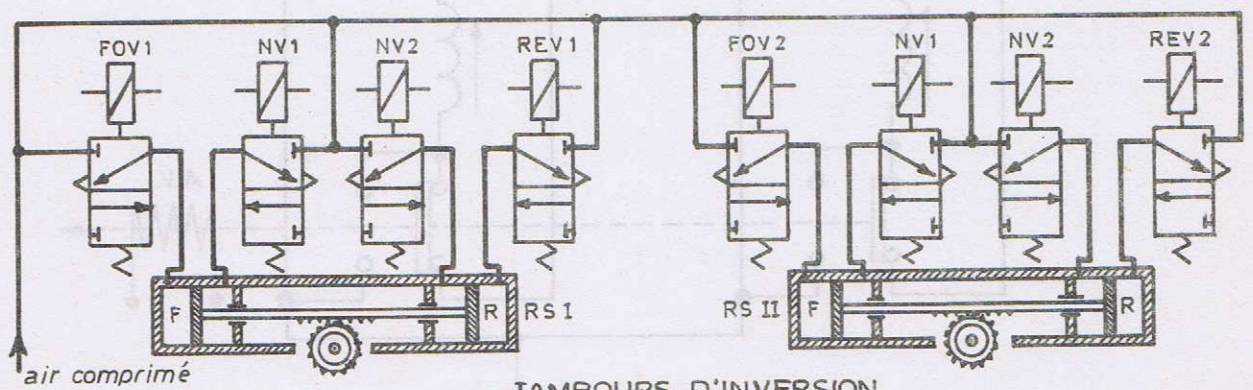

Fig. 107.03.1



TAMBOURS D'INVERSION.

Fig. 107.03.2



CONTACTEURS D'INVERSION.

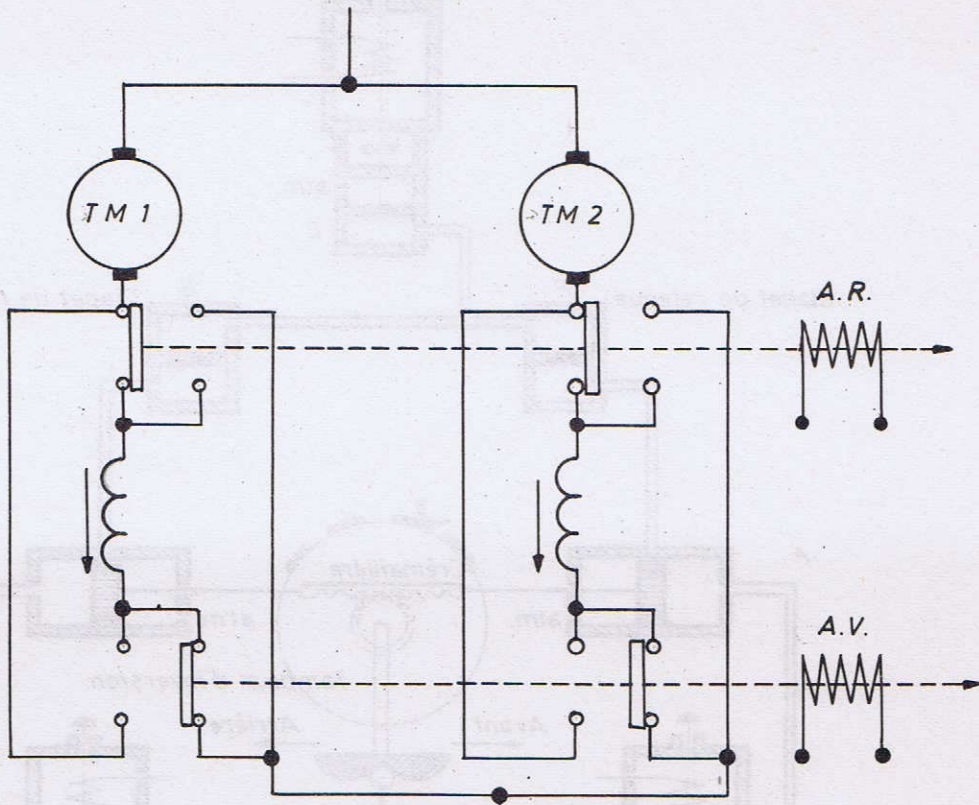

Fig. 107.04.1

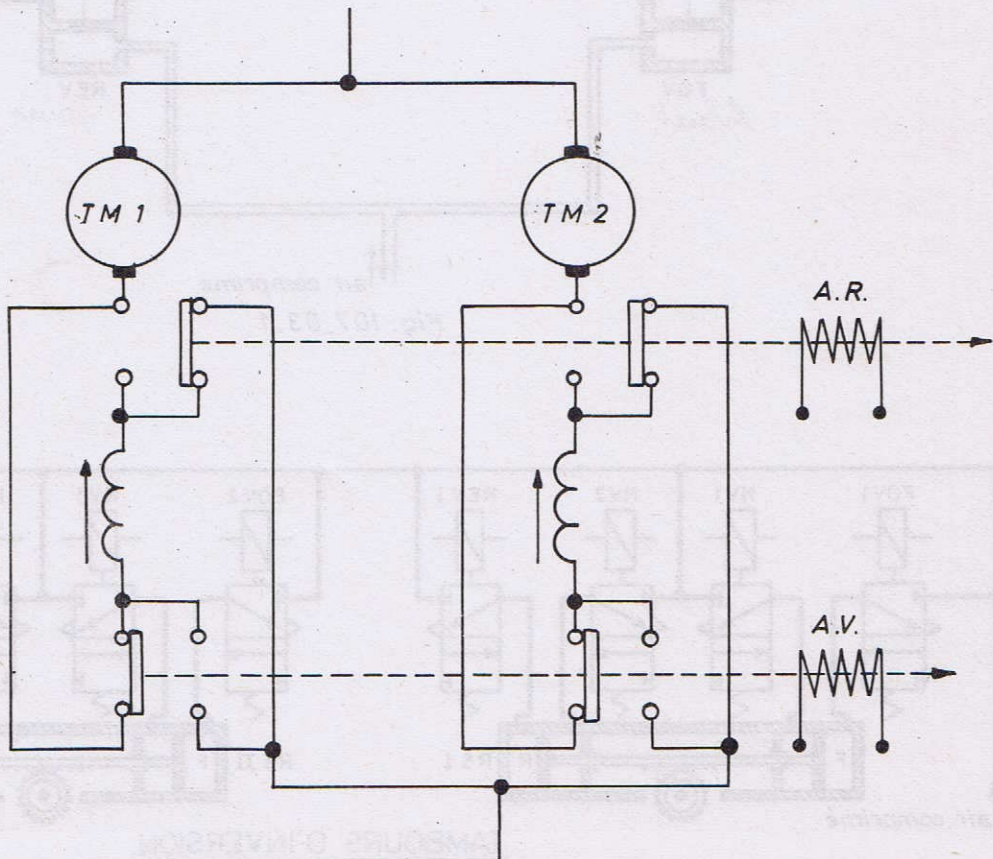

Fig. 107.04.2



**TABLEAU DE  
COURANT  
UNIHORAIRE.**

<i>Intensité maximale</i>	<i>Durée maximum</i>
2.700 Ampères	illimitée
3.000 Ampères	15 minutes
3.600 Ampères	2 minutes
4.200 Ampères	1 minute

Fig. 109.01.1

**PROTECTION CONTRE LE PATINAGE.**

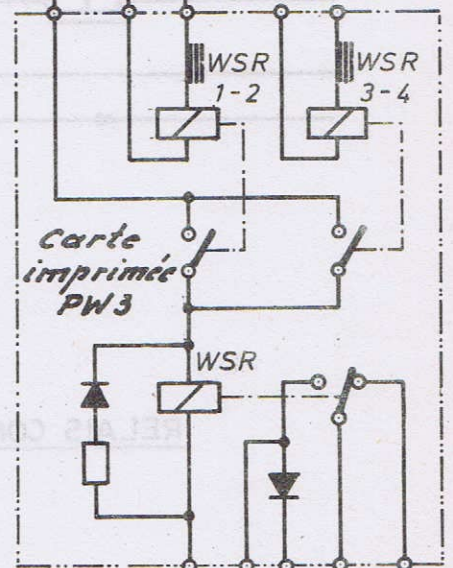
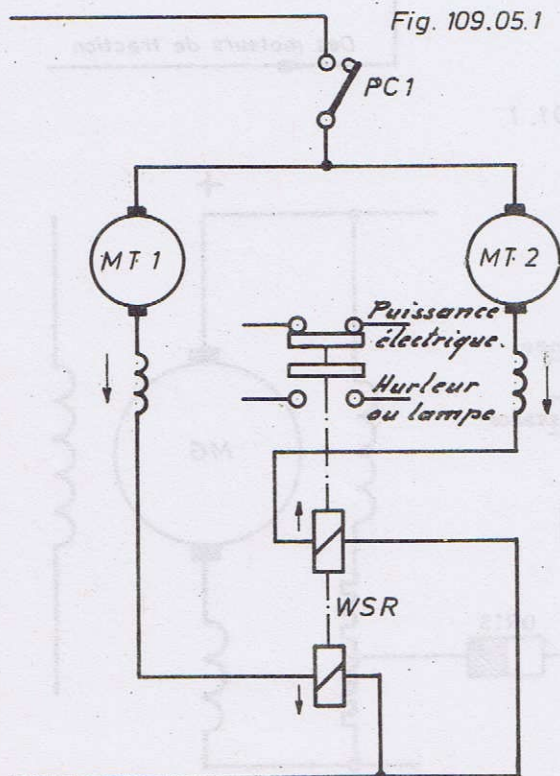
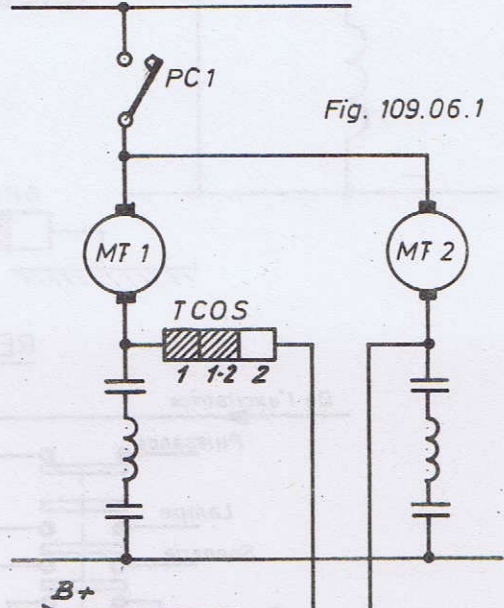
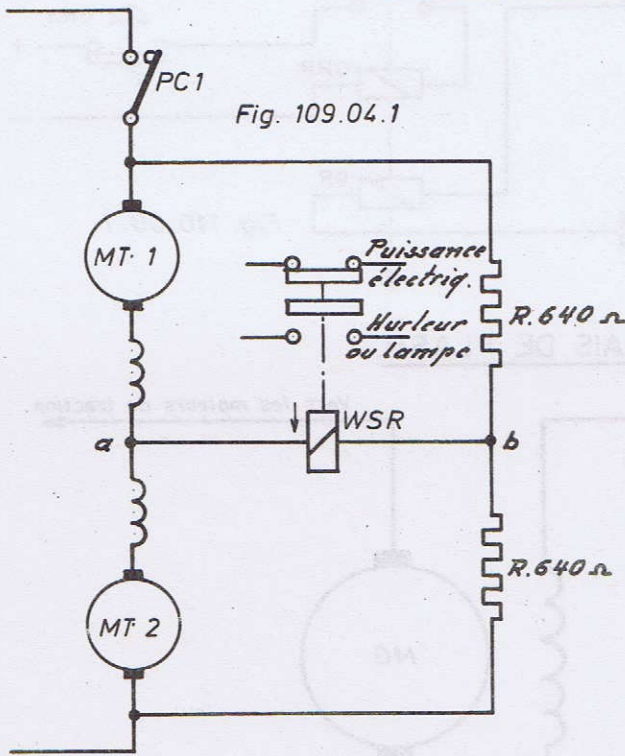

Vers régulateur B1  
Vers lampe témoin  
Du contact de traction de l'accélérateur.  
Vers électrovalve marche à vide.



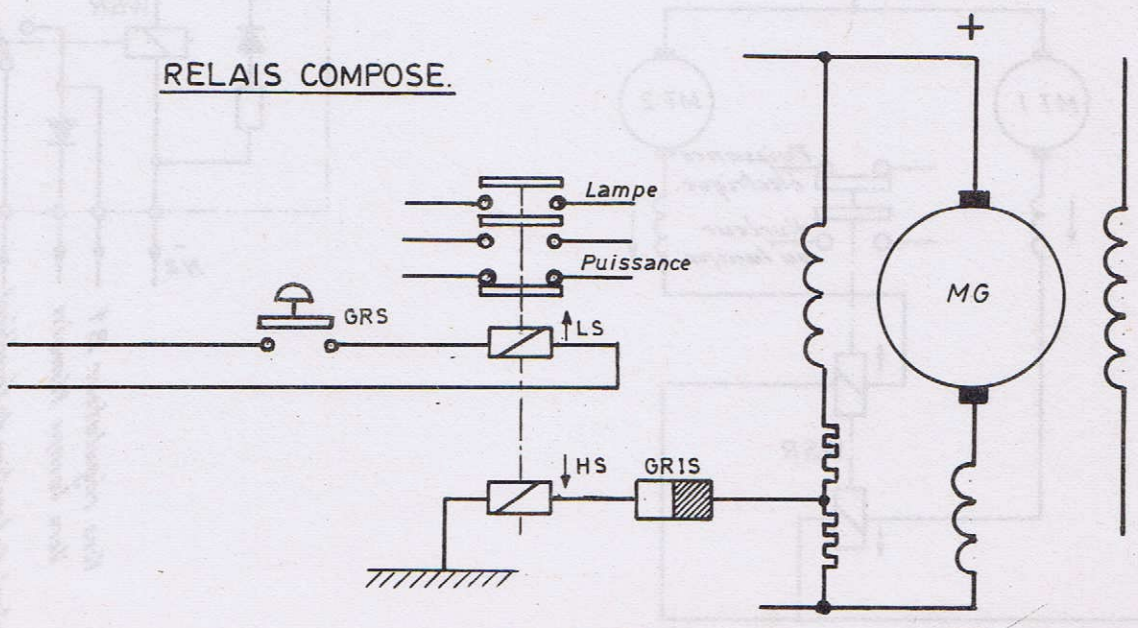
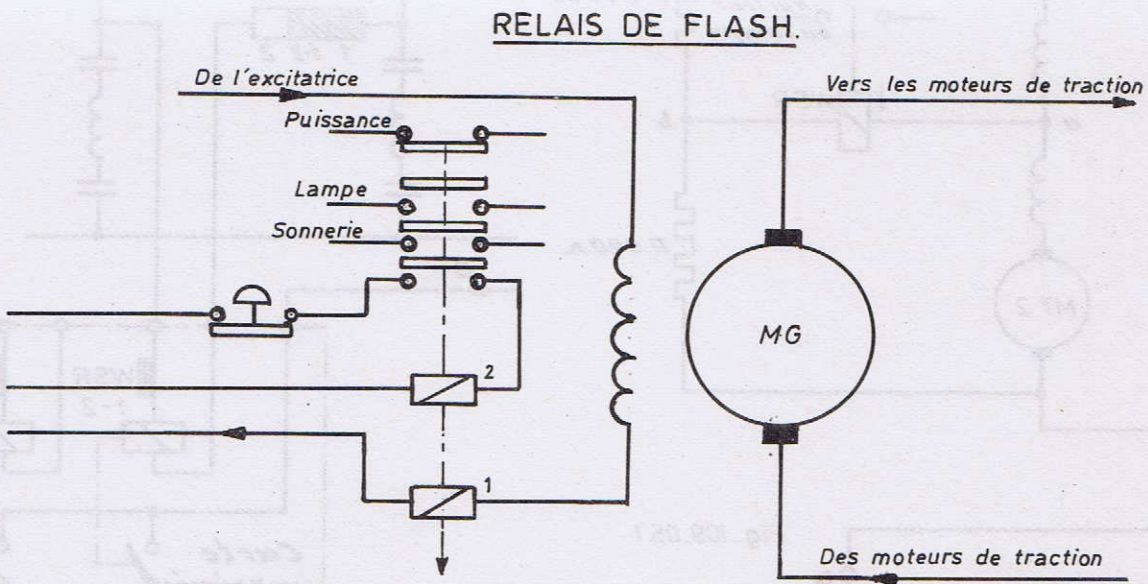
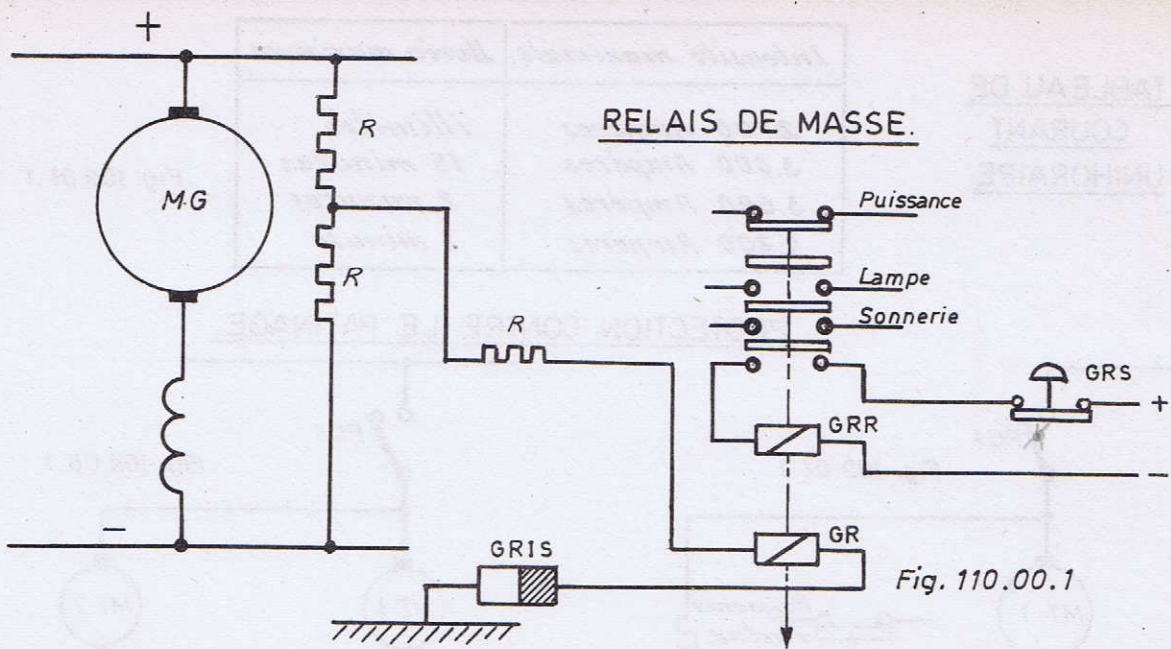



MASSE BASSE TENSION.

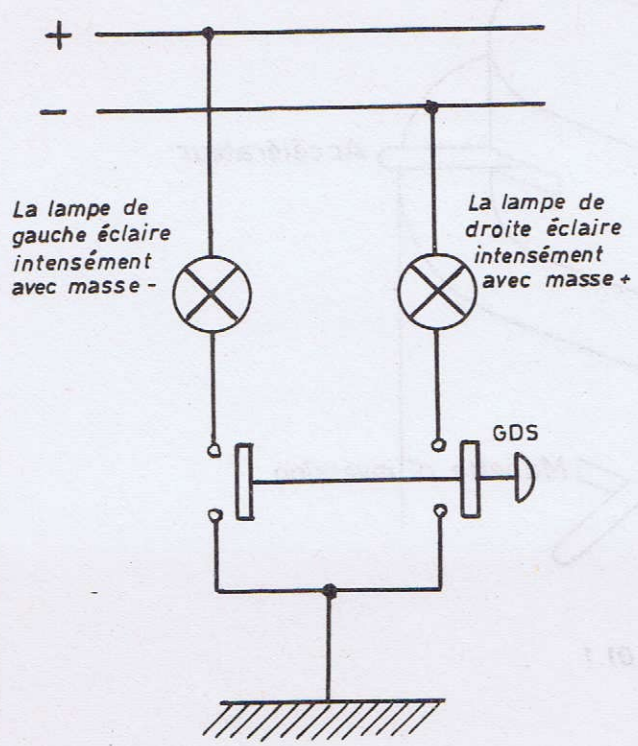

Fig. 110.03.1

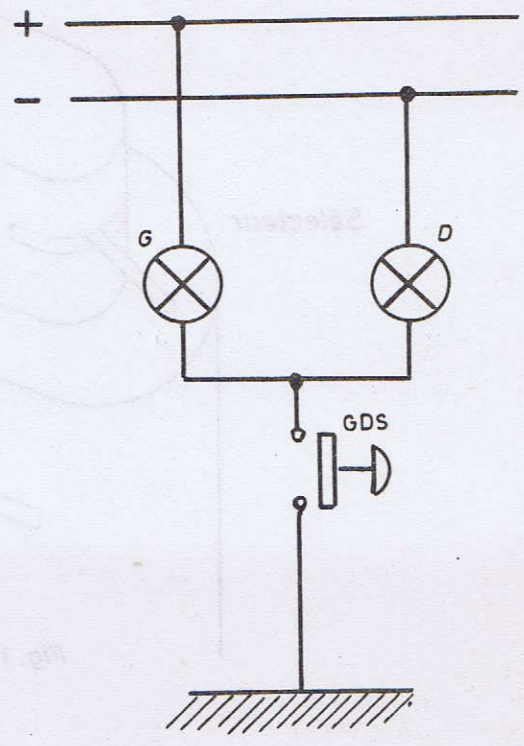

Fig. 110.03.2

FREINAGE RHEOSTATIQUE.

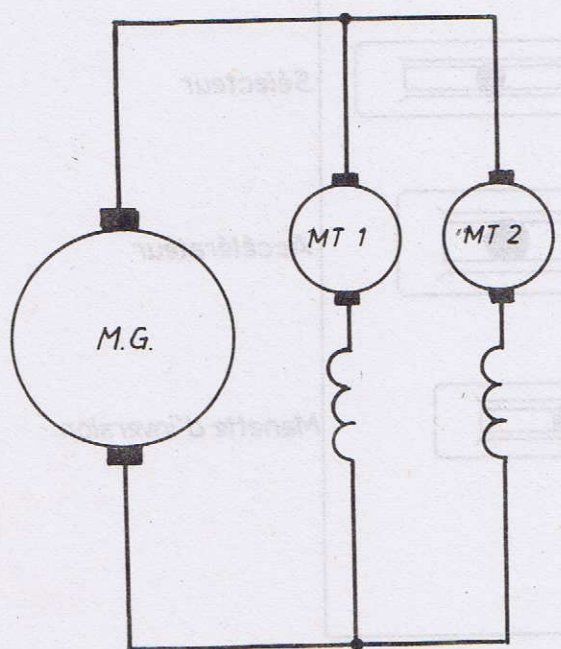

Fig. 111.00.1

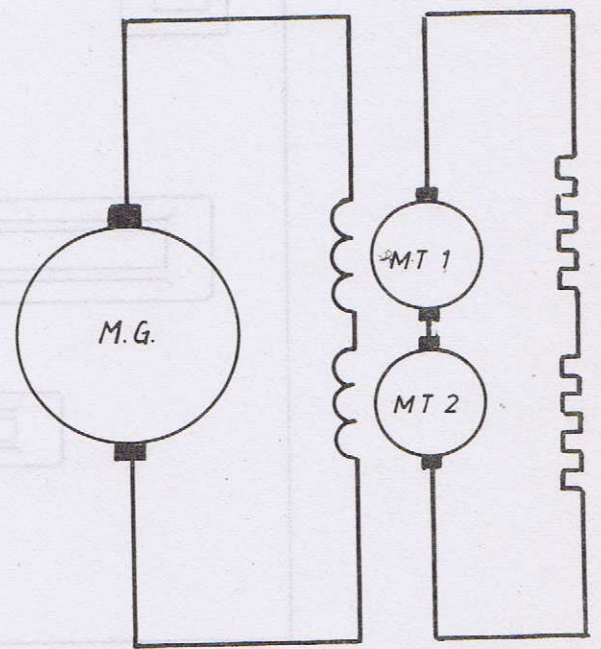

Fig. 111.00.2



## FREINAGE RHEOSTATIQUE.

HLD.E Série 52-53

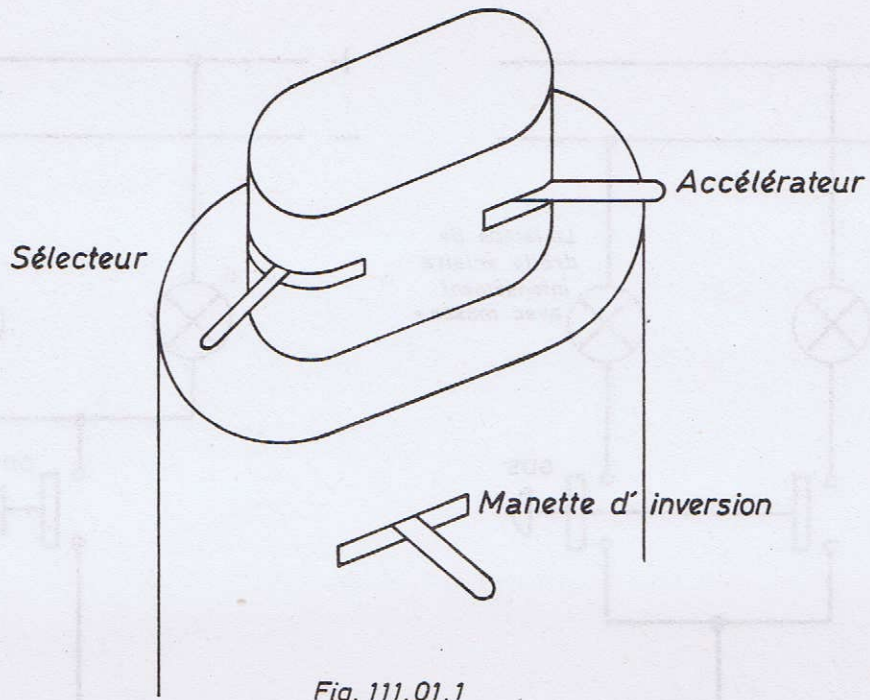

Fig. 111.01.1

HLD.E Série 55

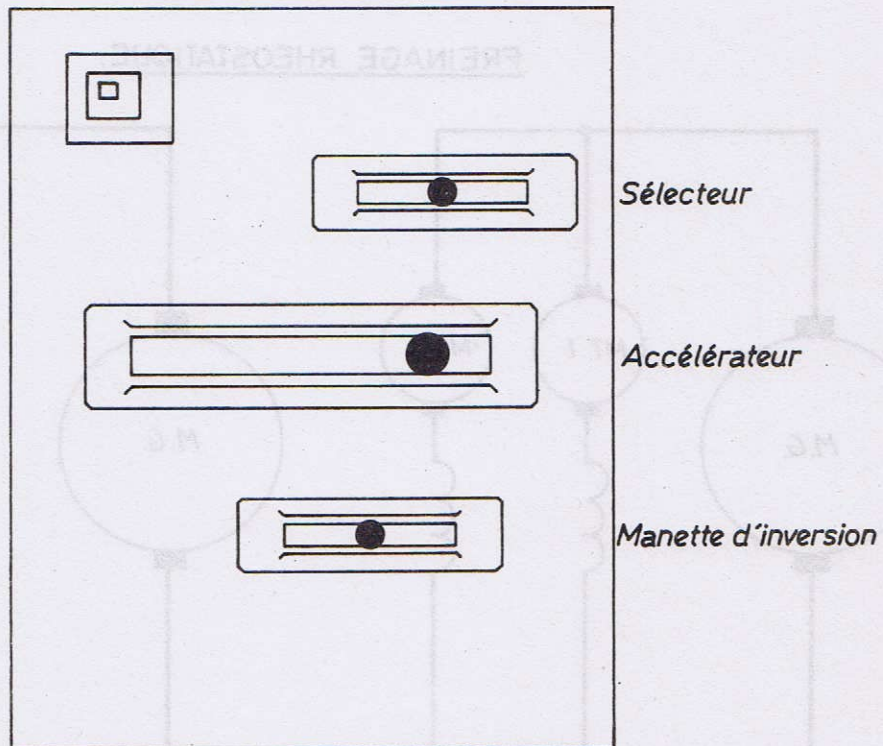

Fig. 111.01. 2



Fig.111.02.1

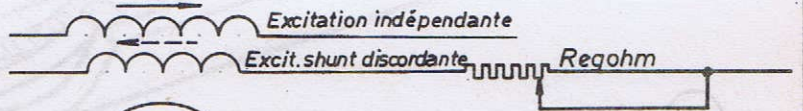
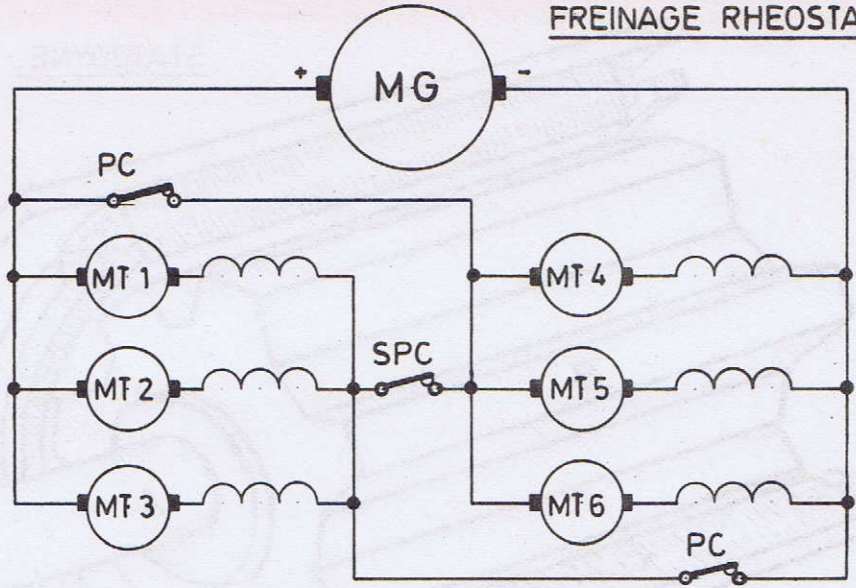

Fig.111.02.2

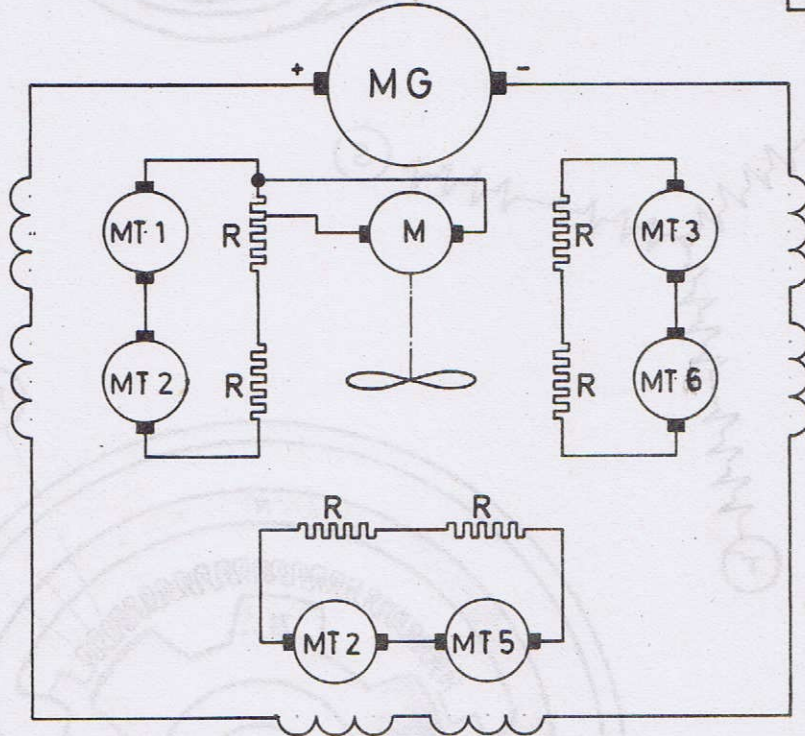
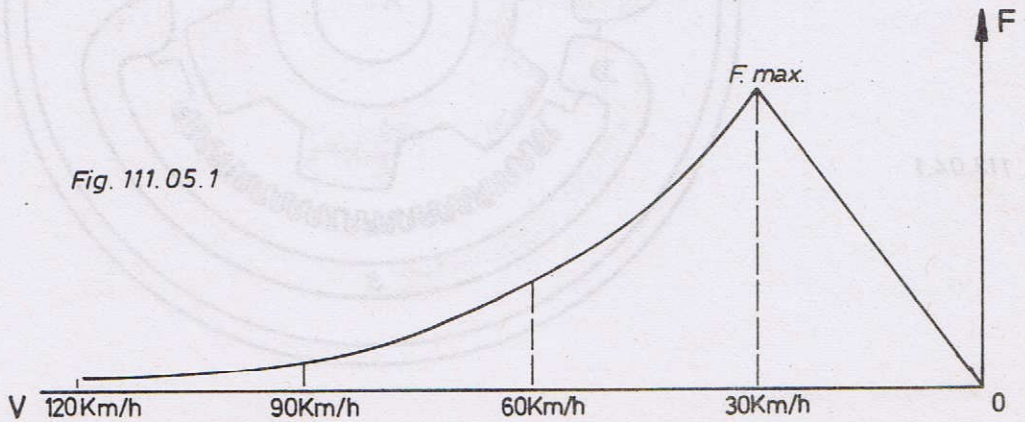

Fig. 111.05.1





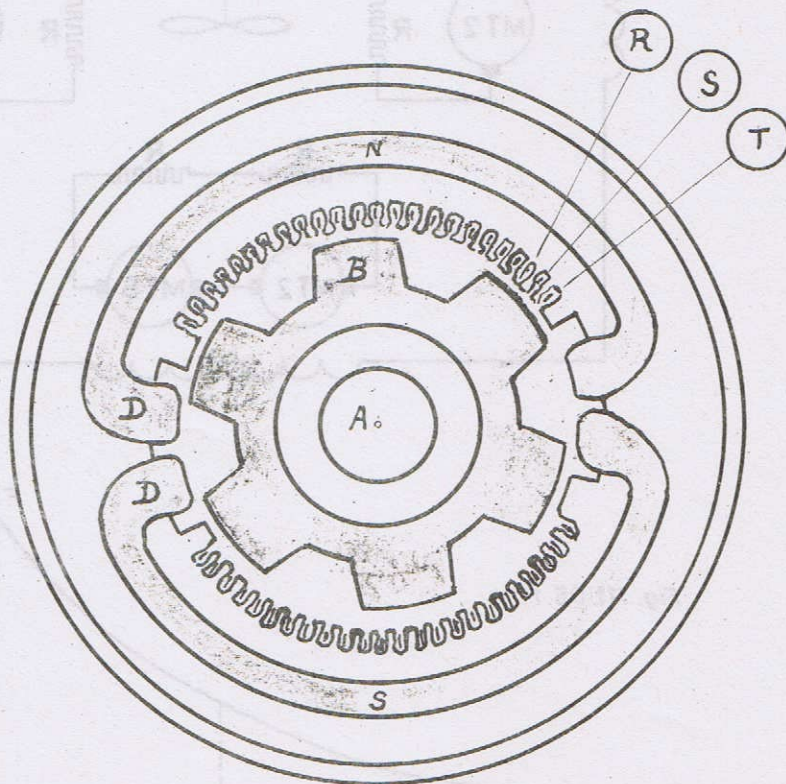
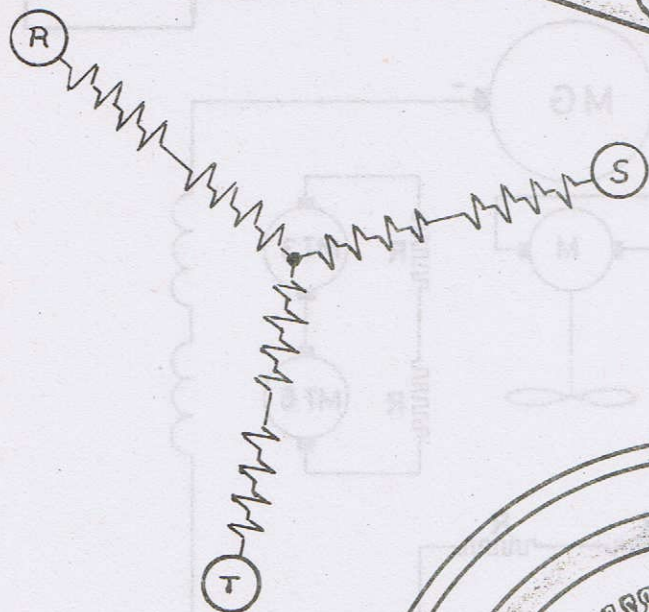
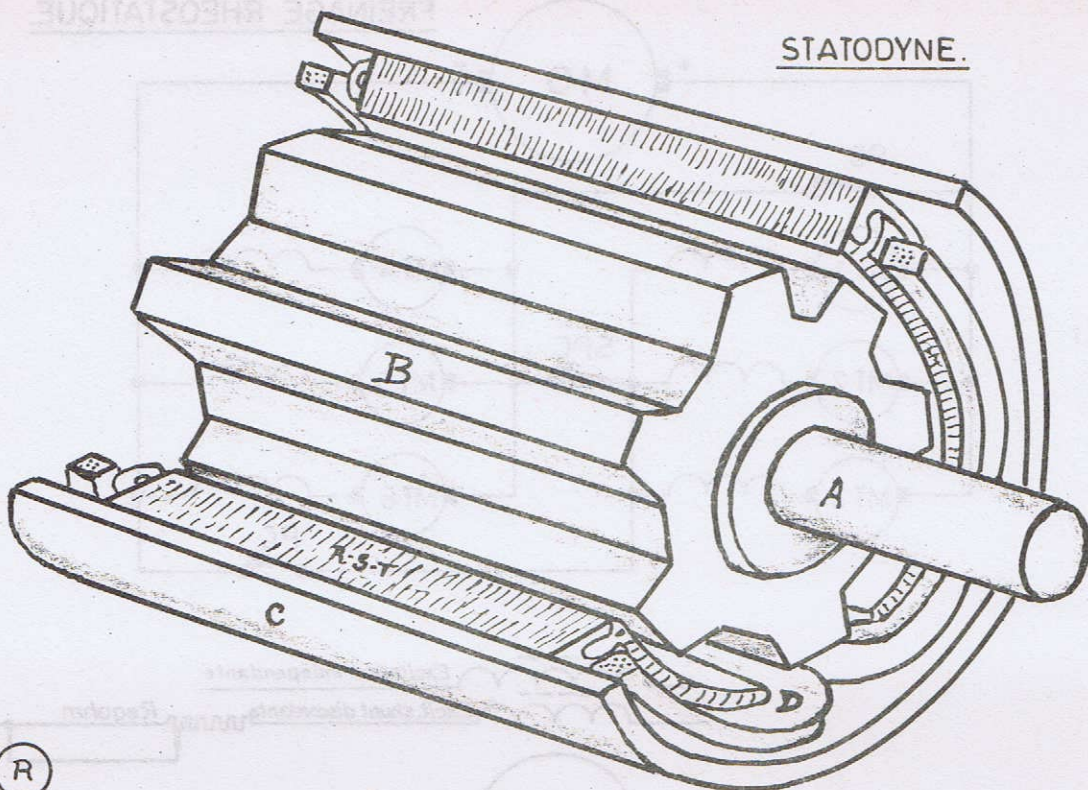

Fig. 113.04.1



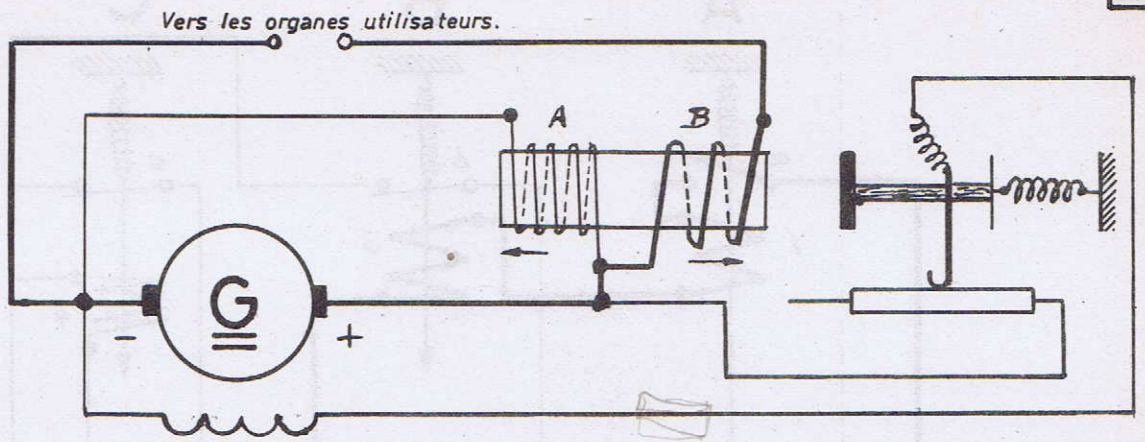

Fig. 114.01.1

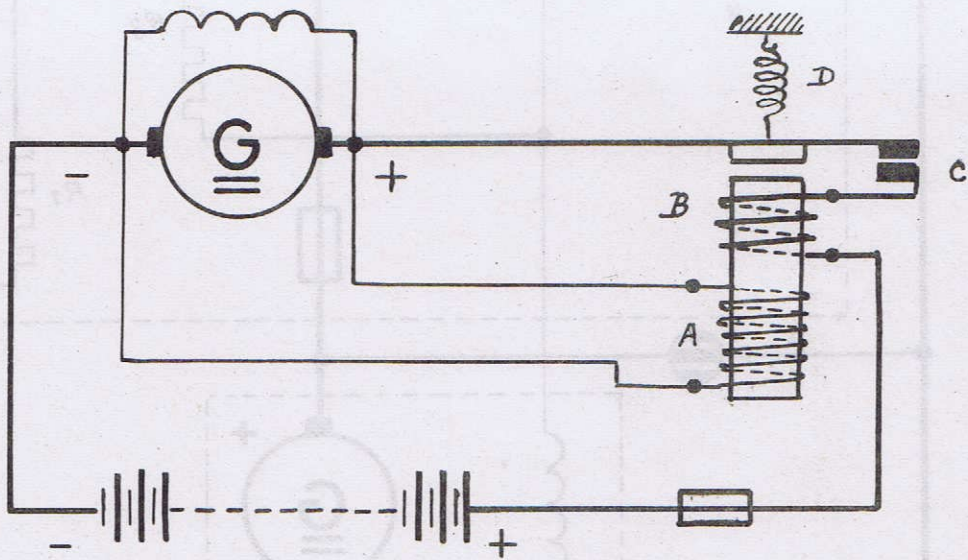

Fig. 114.03.1

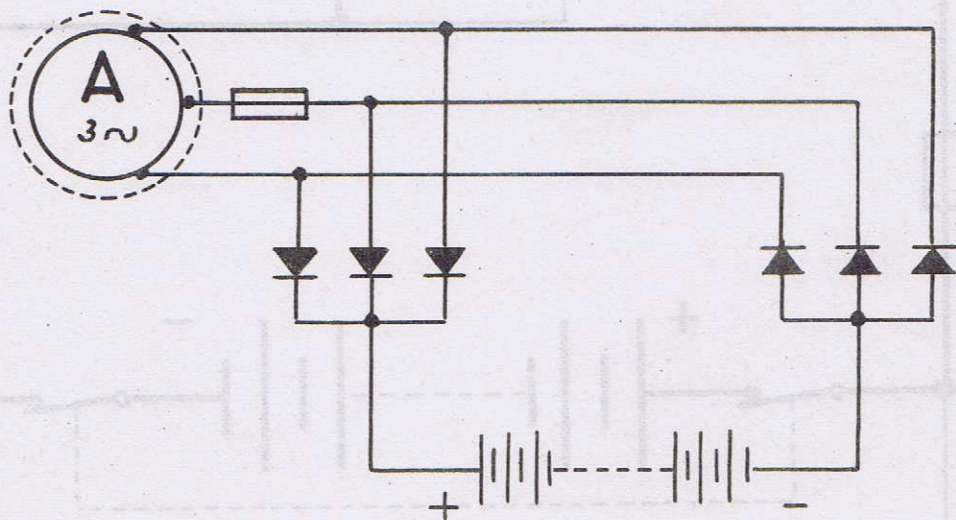

Fig. 114.04.1



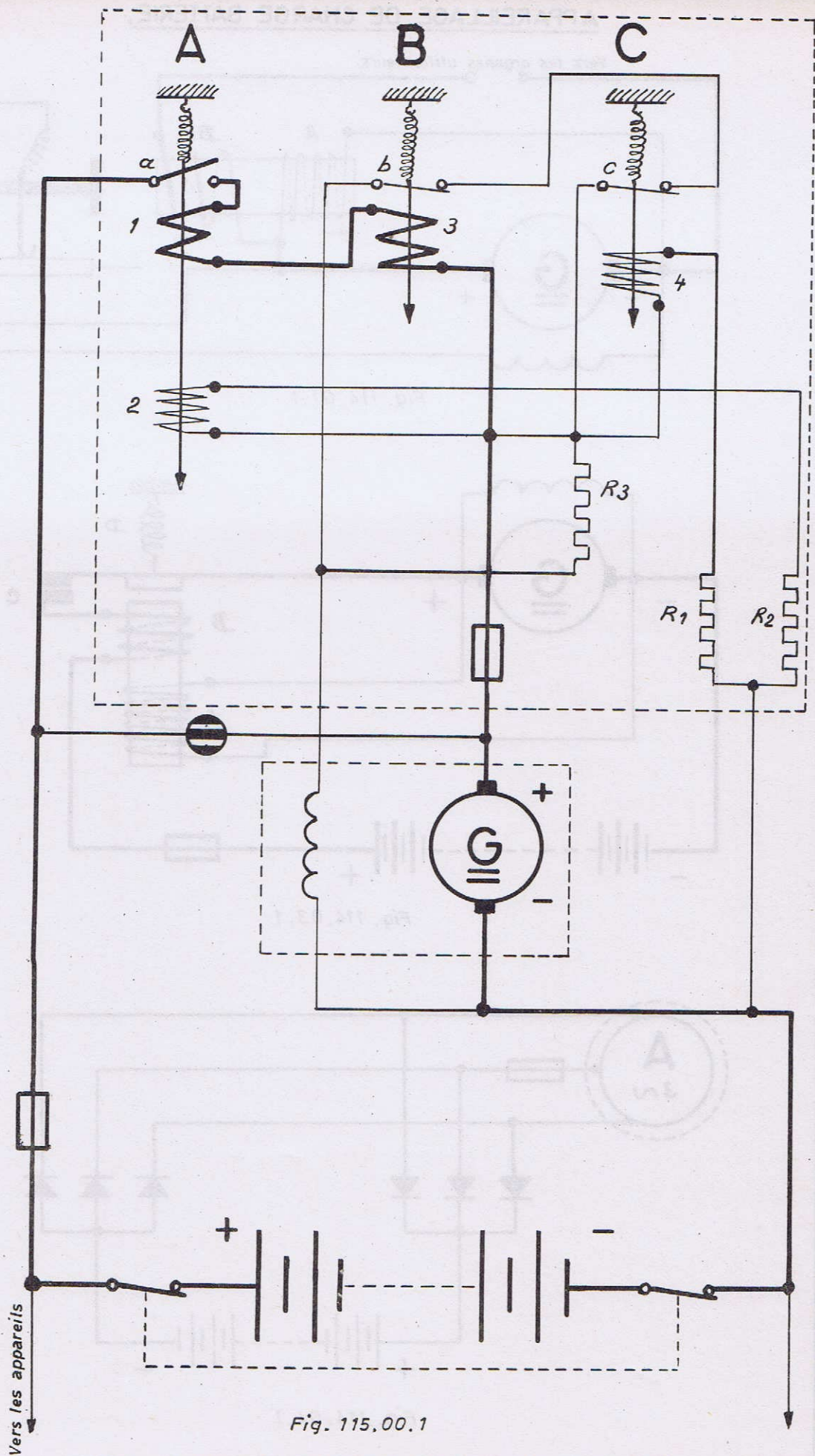

Fig. 115.00.1

REGULATEUR DE TENSION ET CONJONCTEUR DISJONCTEUR.



REGULATEUR DE TENSION

" REGOHM "

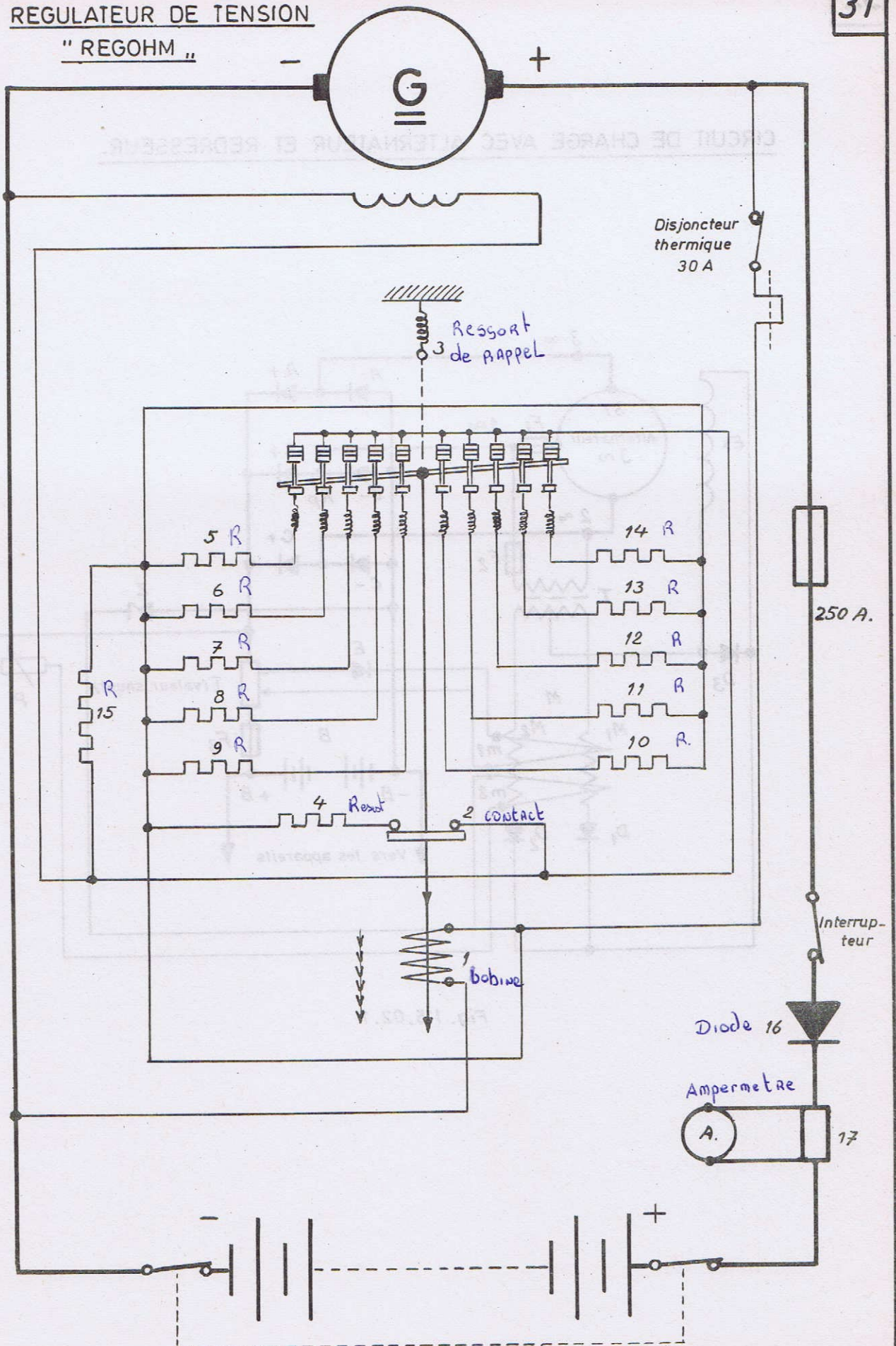

Fig. 115.01.1











VENTILATEURS AVEC MOTEURS A COURANT CONTINU.

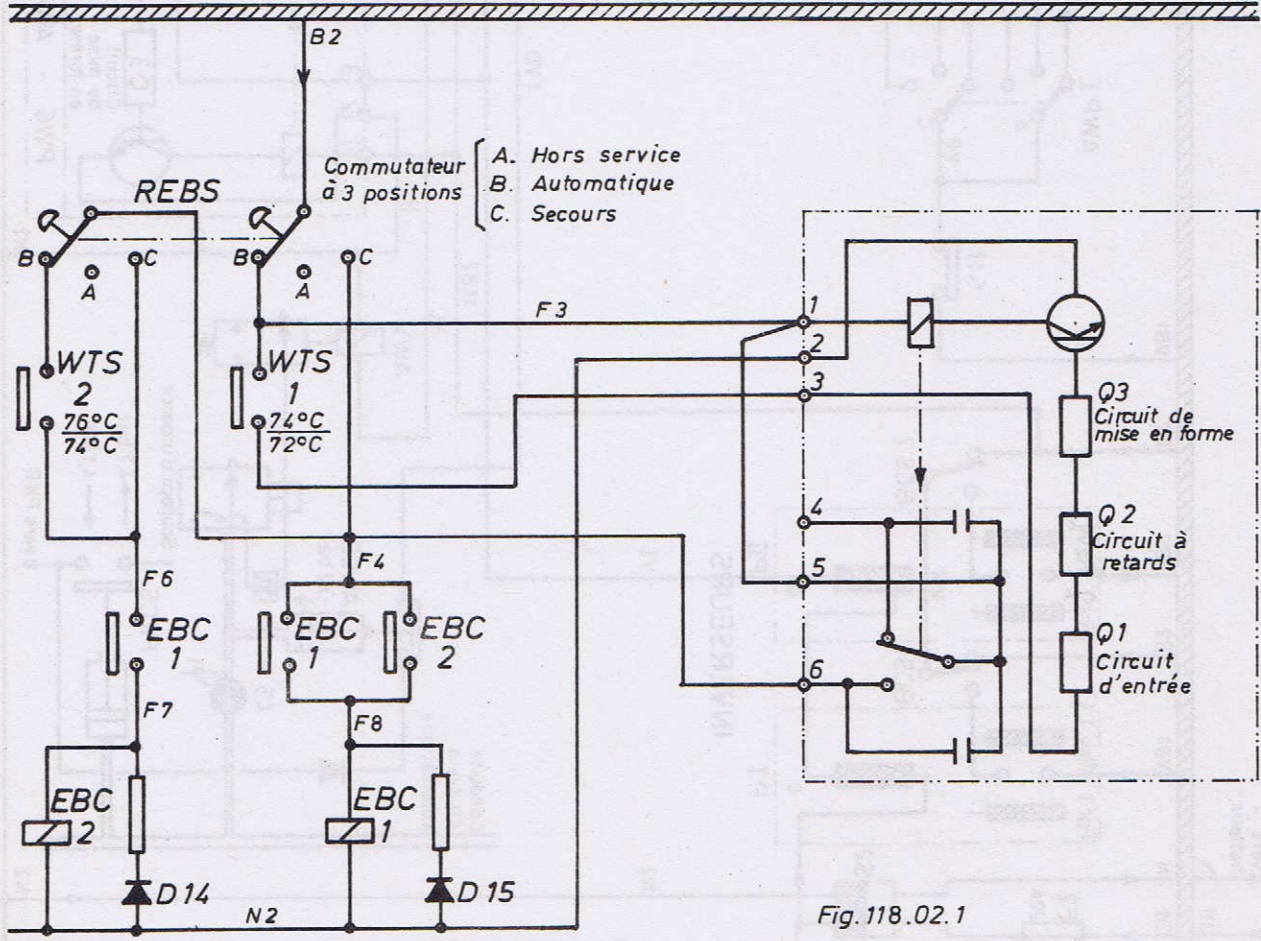
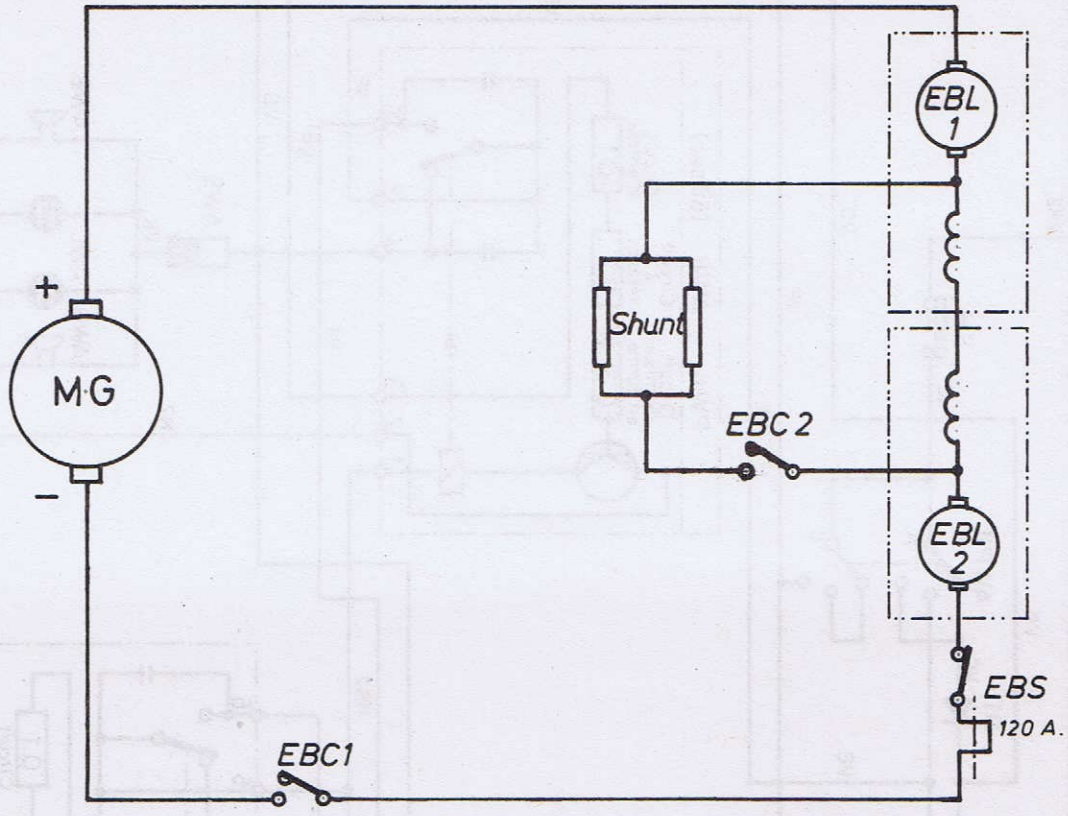

Fig. 118.02.1



VENTILATEURS ENTRAINES PAR MOTEURS A COURANT ALTERNATIF.

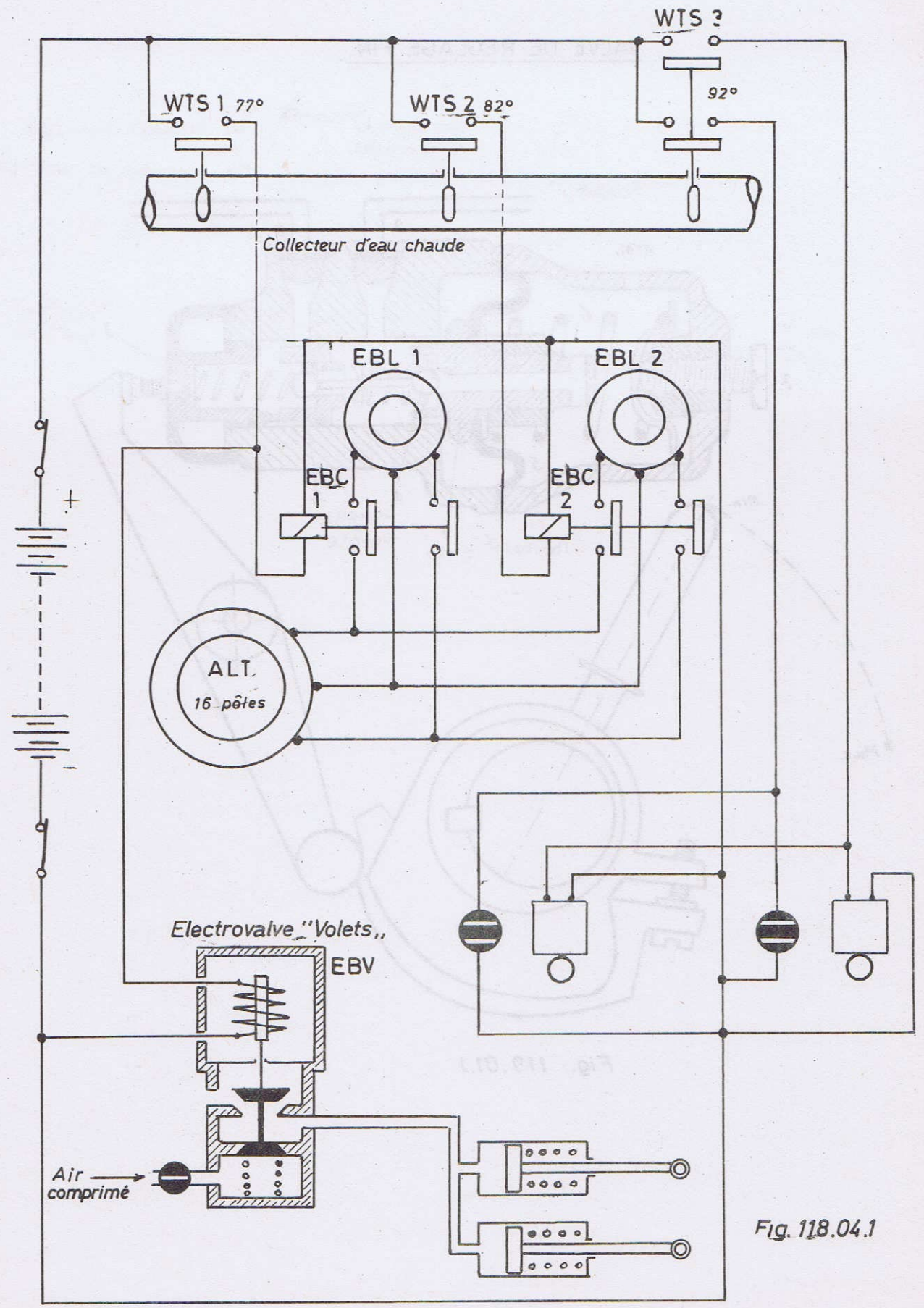

Fig. 118.04.1



VALVE DE REGLAGE FIN.

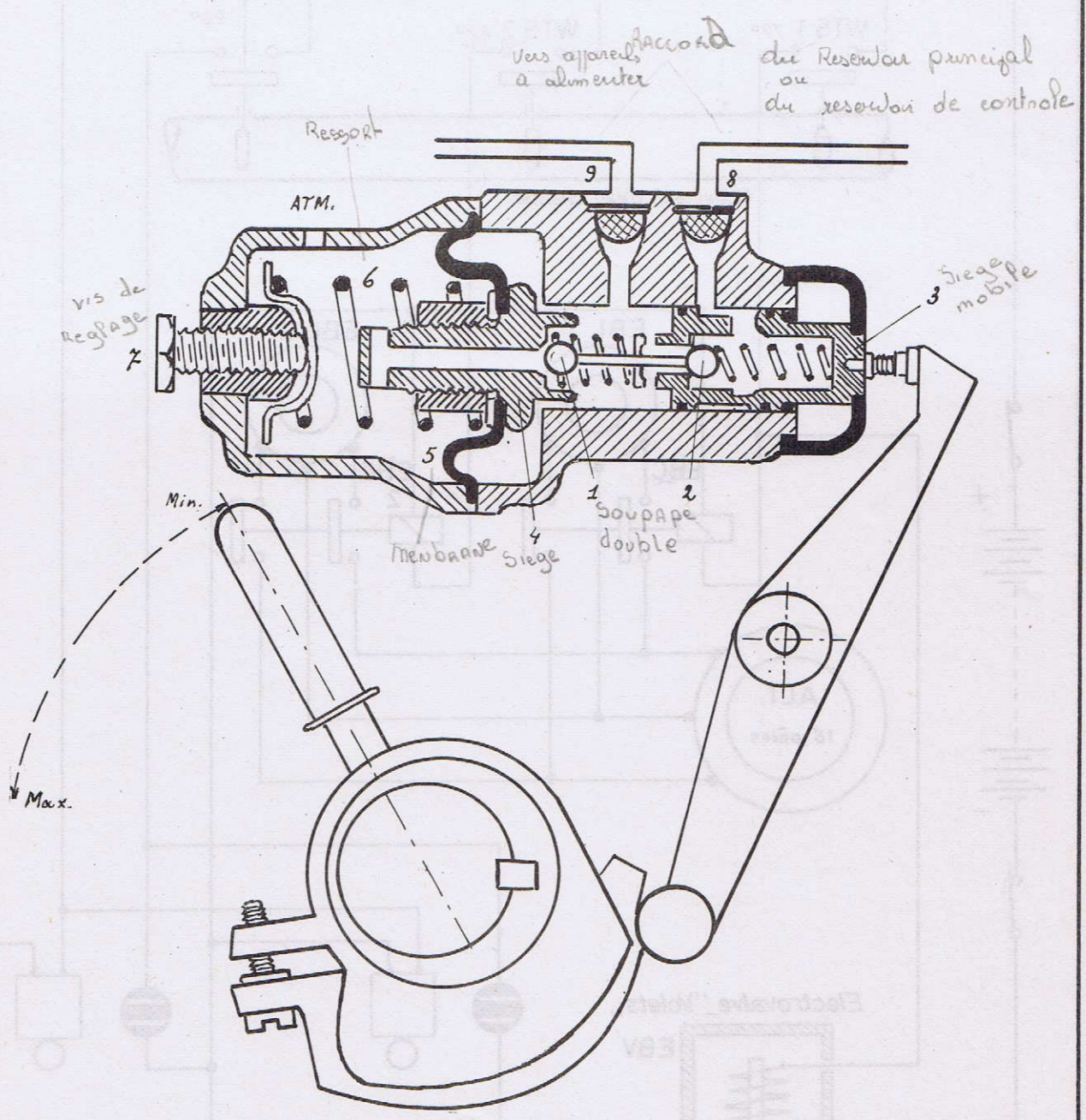

Fig. 119.01.1



# ACCELERATION A COMMANDE PNEUMATIQUE.

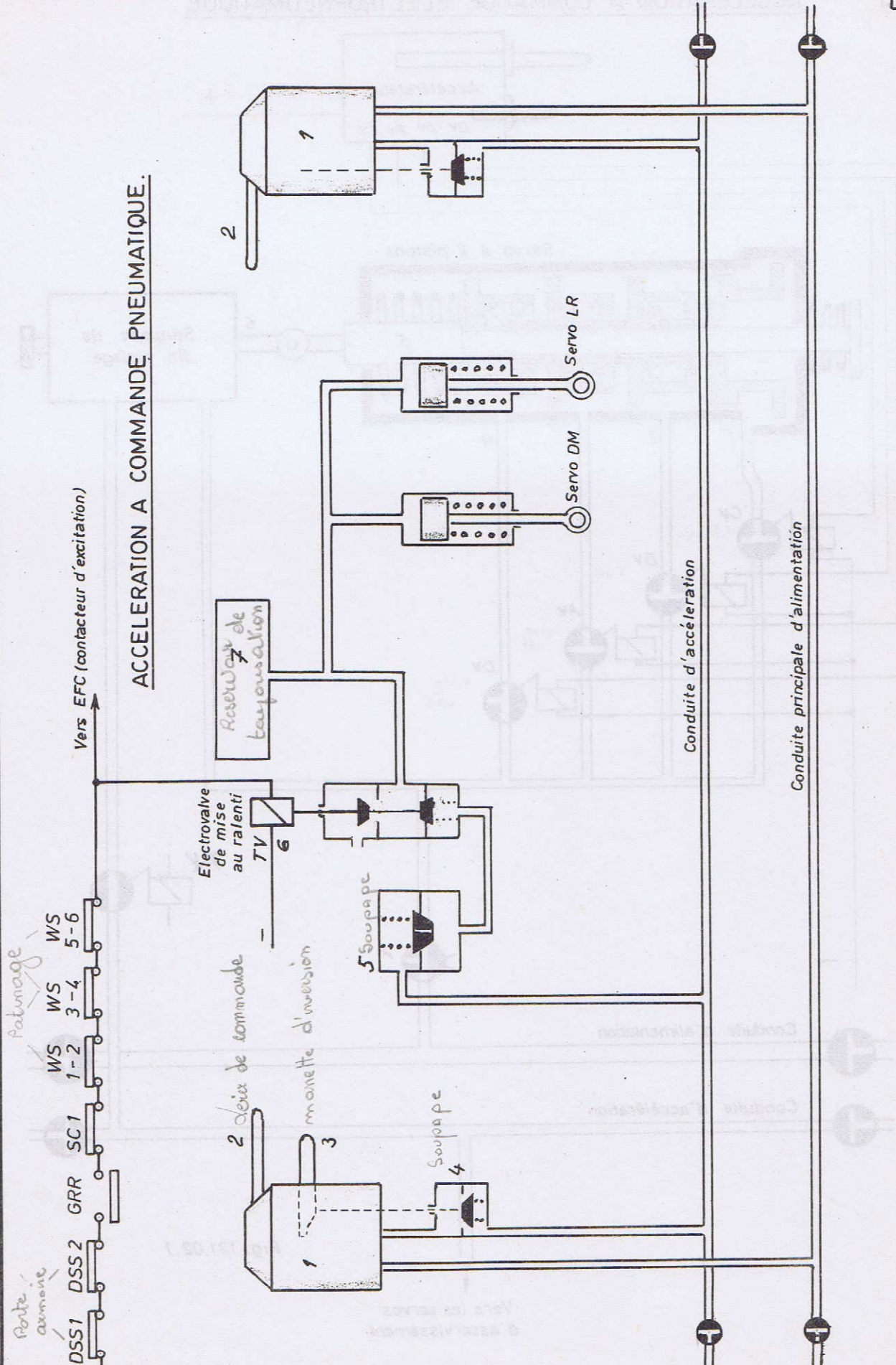

Fig. 121.01.1



ACCELERATION A COMMANDE ELECTROPNEUMATIQUE.

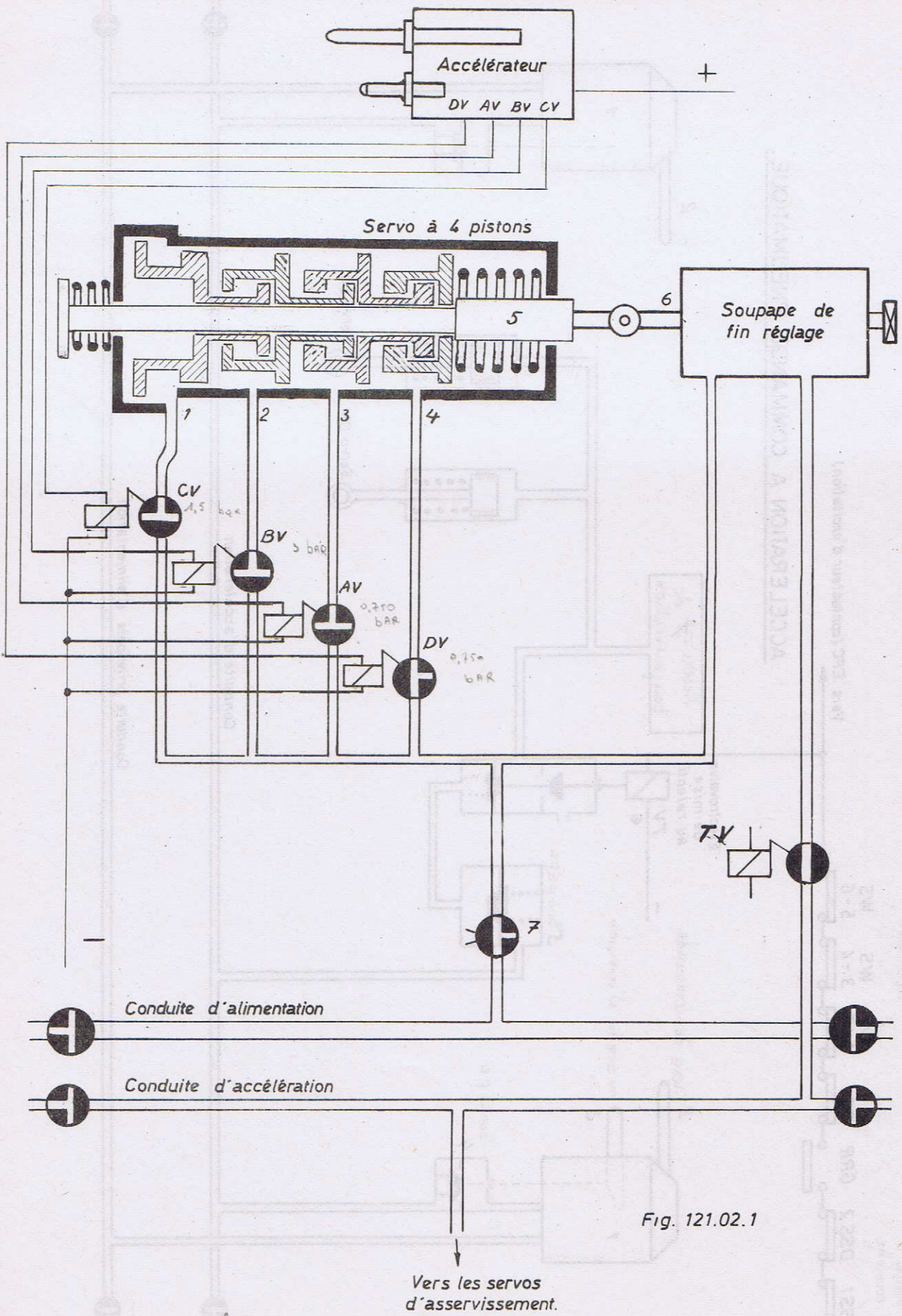

Fig. 121.02.1



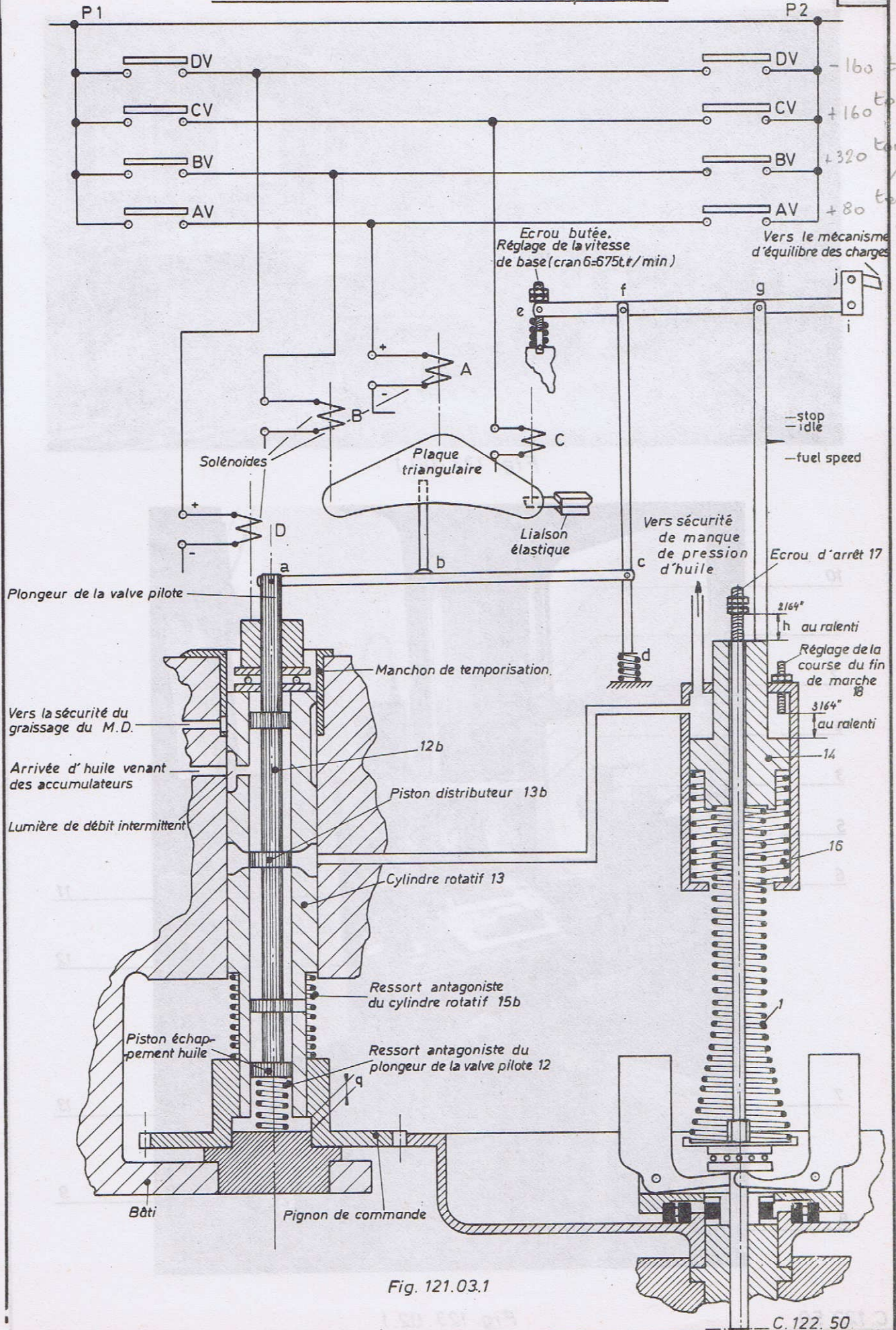

Fig. 121.03.1



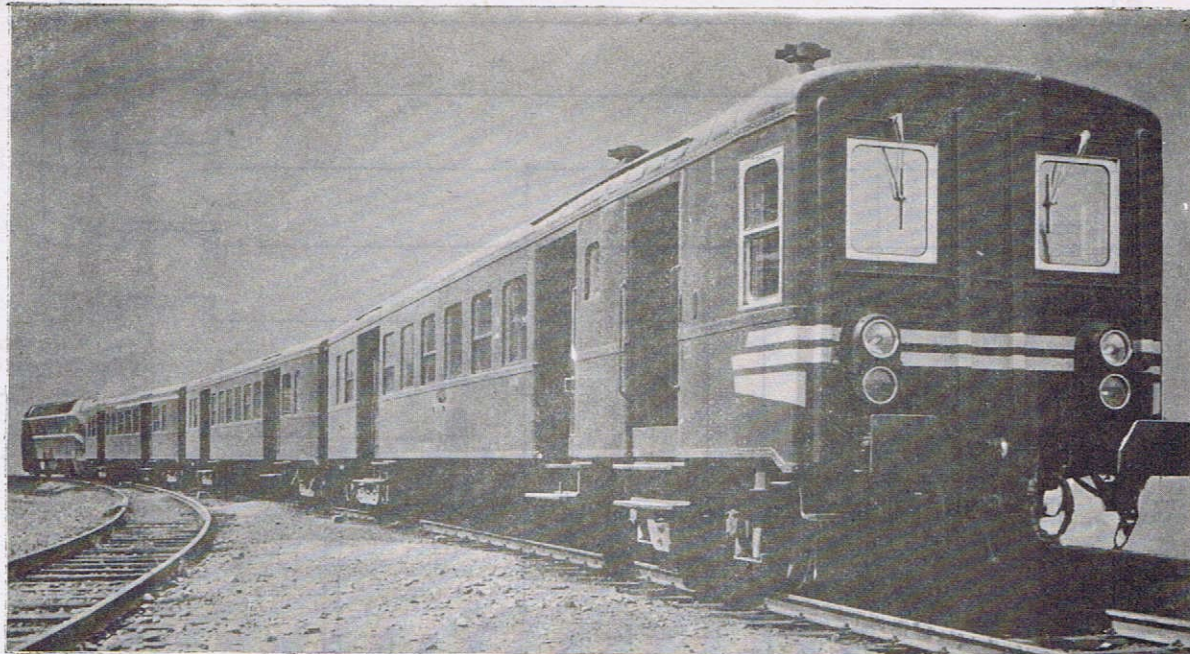

Fig. 123. 00.1

10

1

2

4

3

5

6

11

12

7

13

8

9





## COFFRET D'ALIMENTATION (ancien modèle).

1. Interrupteur réseau 220 Volts.
2. Interrupteur thermique avec bouton de réarmement.
3. Voltmètre 72 Volts.
4. Fusibles 15 Amp.
5. Lampe témoin.
6. Prise pour raccordement alternatif 220 V.
7. Prise pour raccordement courant continu 72 V.

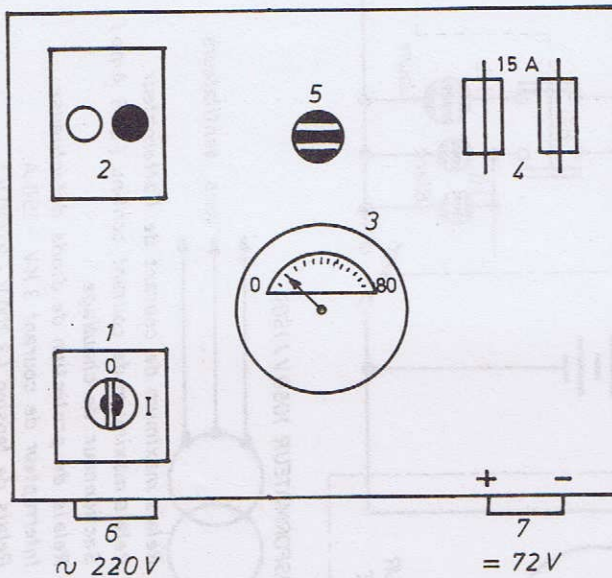

Fig. 127.00.1

## COFFRET D'ALIMENTATION (nouveau modèle).

1. Interrupteur 220 Volts.
2. Interrupteur thermique sur circuit alternatif E1.
3. Interrupteur thermique sur circuit continu E2.
4. Lampe de contrôle de tension alternative (rouge).
5. Lampe de contrôle de tension continue (bleue).

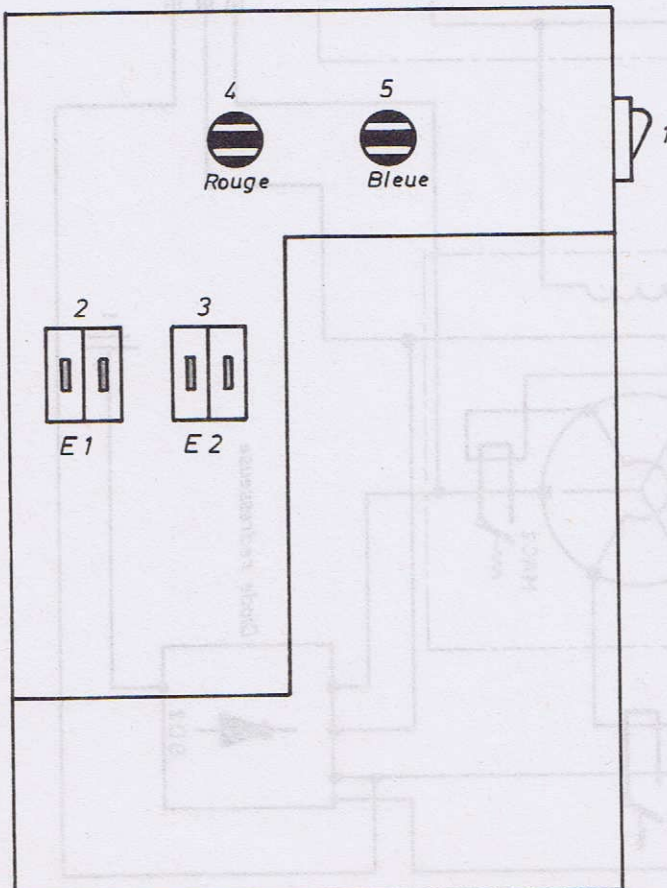

Fig. 127.01.1



SCHEMA DE PRINCIPE DU FOURGON DE CHAUFFAGE.

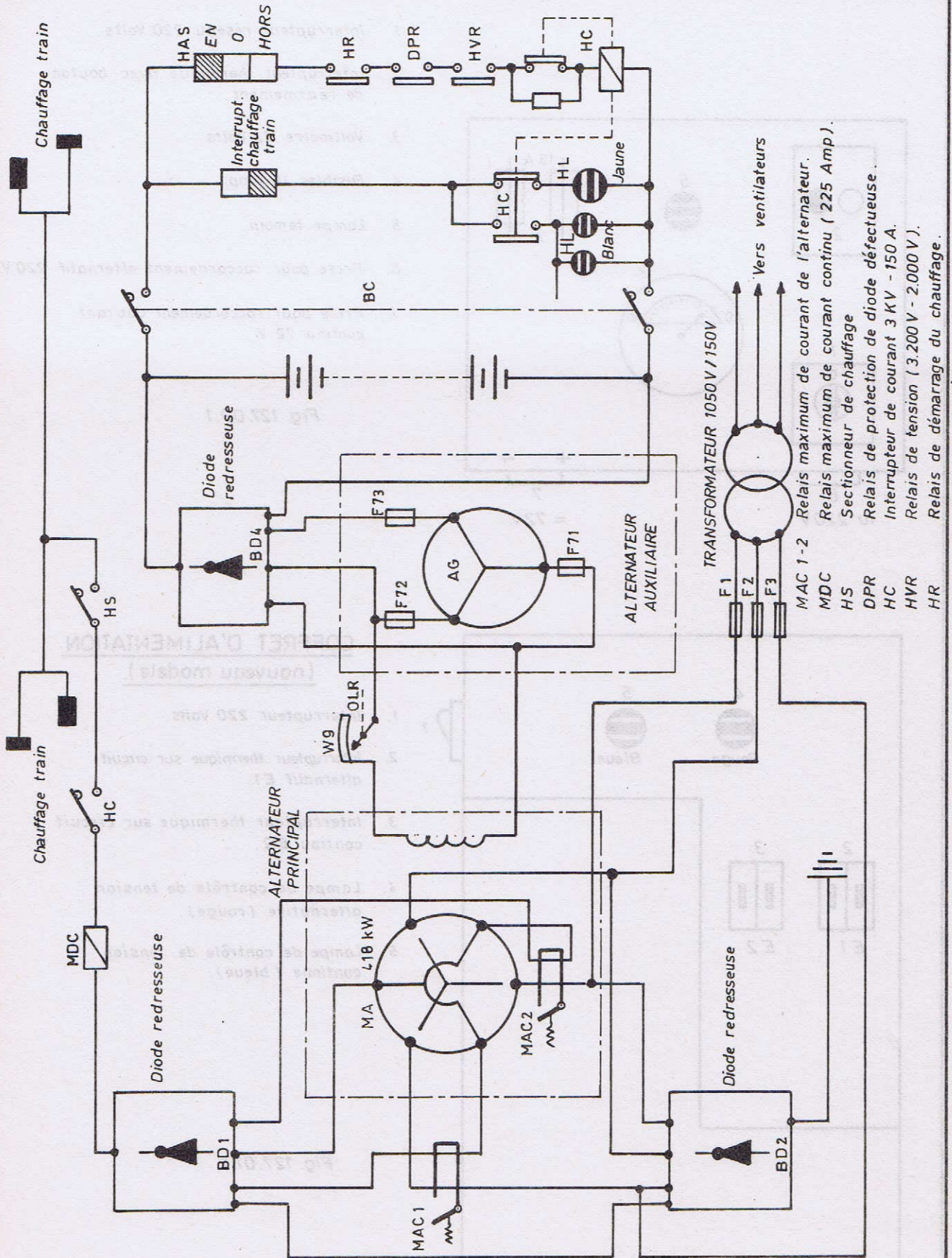
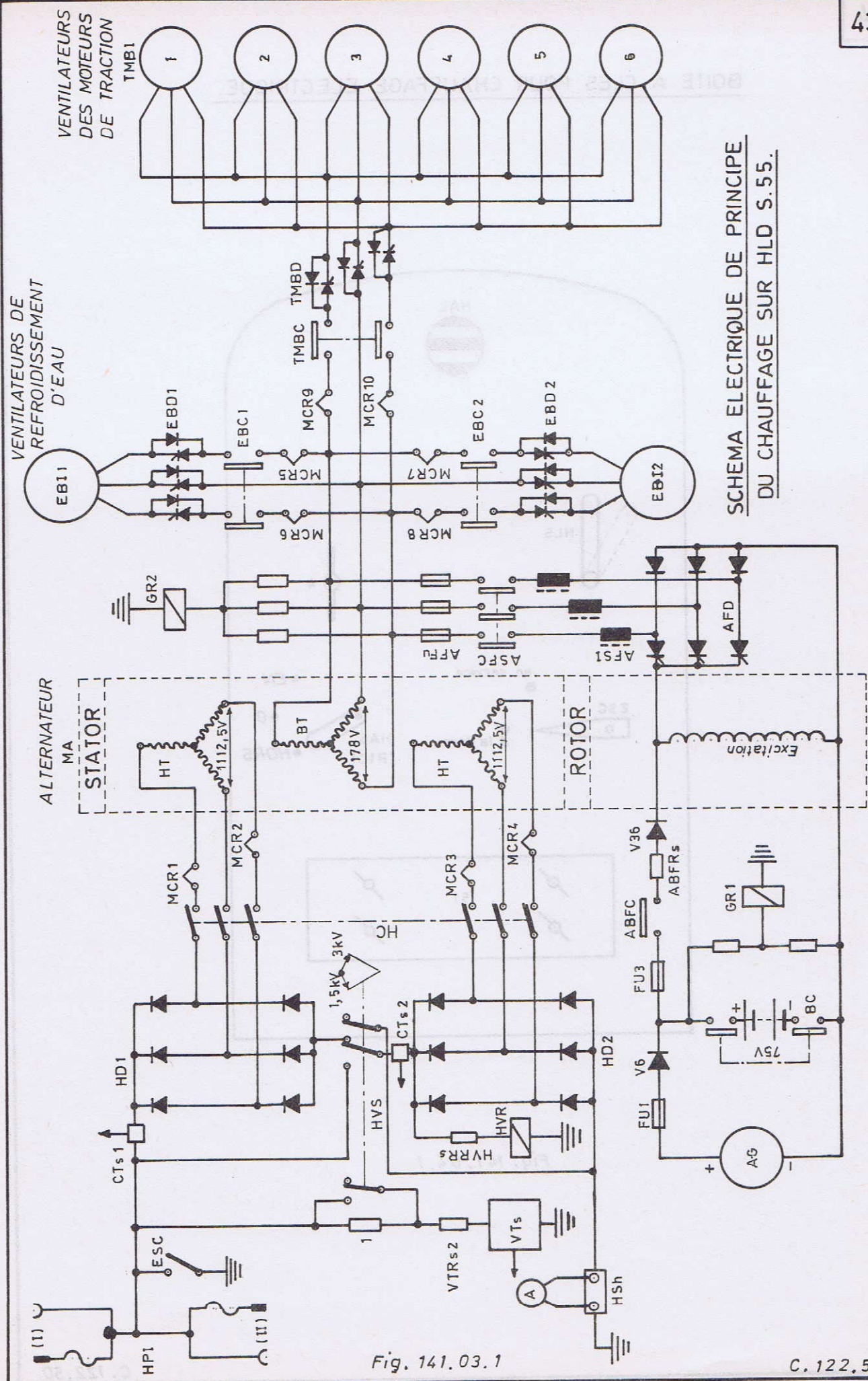

Fig. 141. 01. 1





SCHEMA ELECTRIQUE DE PRINCIPE  
DU CHAUFFAGE SUR HLD S.55.

Fig. 141.03.1



BOITE A CLES POUR CHAUFFAGE ELECTRIQUE.

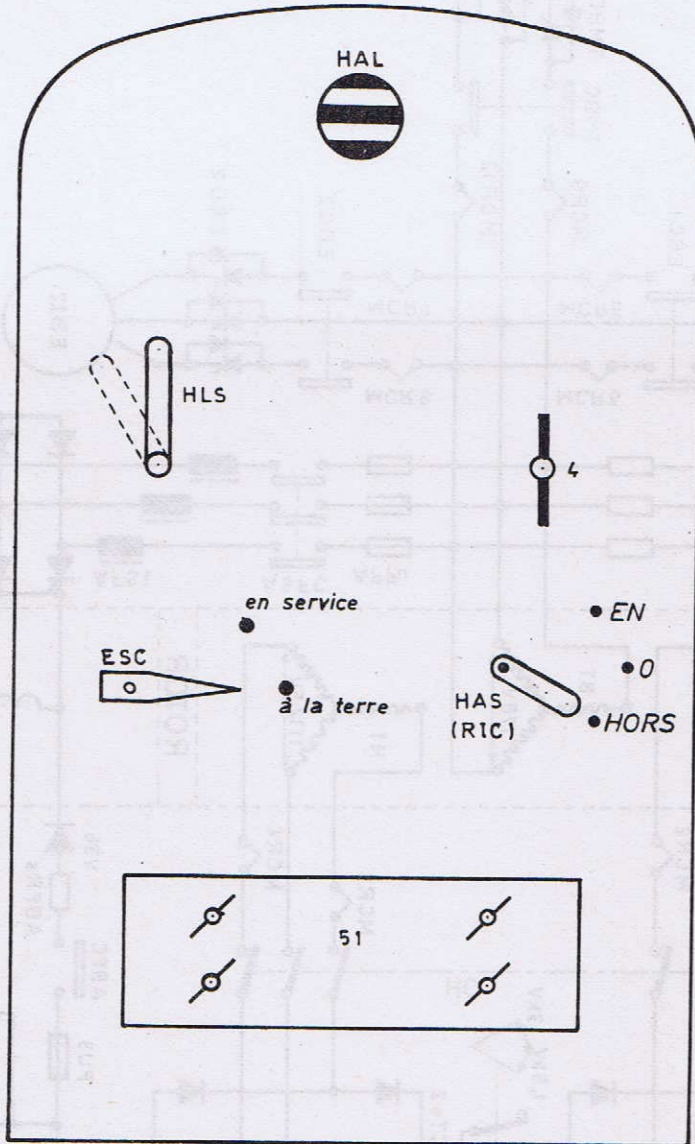

Fig. 141. 04. 1



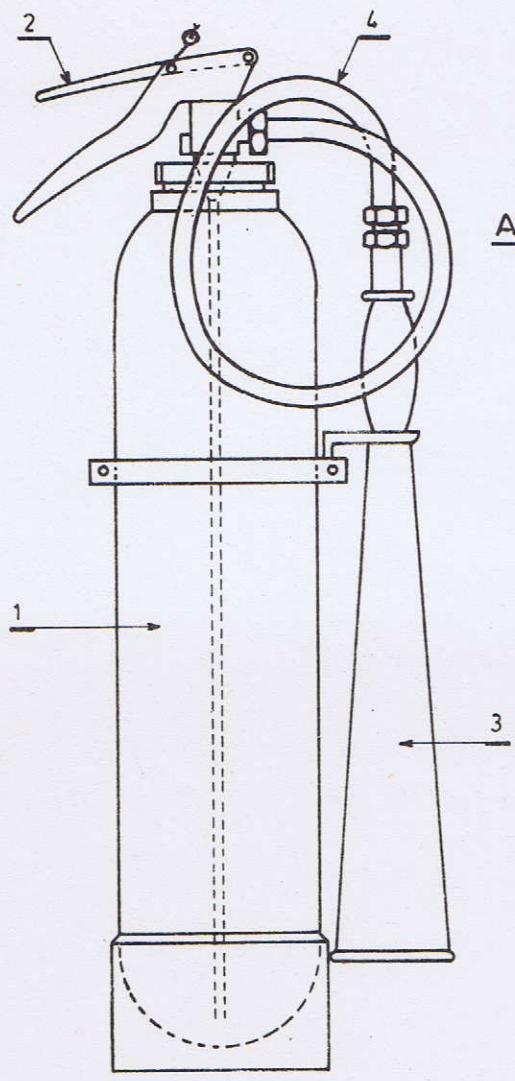

Fig. 143.02.1

APPAREIL A CO<sub>2</sub>.

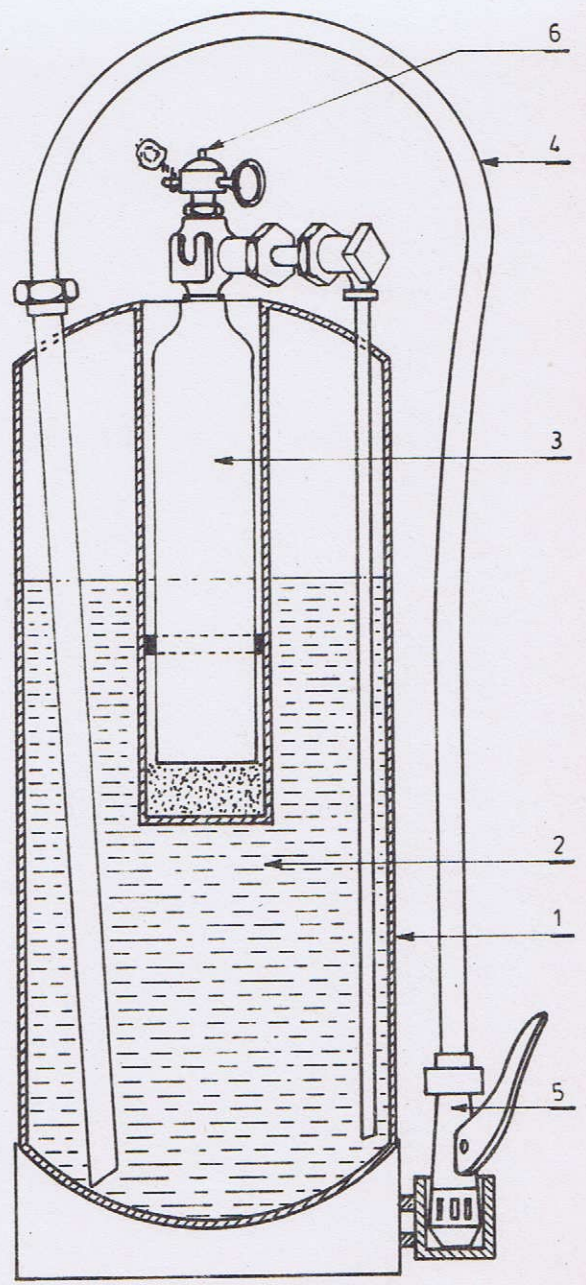

Fig. 143.04.1

APPAREIL A POUVRE.



















